



MICROMISER 12 & 16 ATOMISERS AND CONTROLLER

**Operator's Handbook
and
Parts Catalogue**

Micron Sprayers Limited
Bromyard Industrial Estate
Bromyard
Herefordshire HR7 4HS
United Kingdom

Telephone: +44 (0) 1885 482397
Fax: +44 (0) 1885 483043
E-mail: micron@micron.co.uk
Web site: www.micron.co.uk

Iss 4W
11/2021

TABLE OF CONTENTS

1.	INTRODUCTION.....	1
2.	SPECIFICATION.....	2
2.1.	Atomiser.....	2
2.2.	Segmental Attachment.....	2
2.3.	Controller.....	3
3.	INSTALLATION.....	5
3.1.	Atomiser.....	5
3.1.1.	Mounting – Basic Atomiser.....	5
3.1.2.	Mounting – with Segmental Attachment.....	6
3.2.	Liquid Feed.....	8
3.3.	Liquid Drain.....	9
3.4.	Motor Venting.....	9
3.5.	Electrical Connections.....	10
3.5.1.	Use with Micronair Controller.....	10
3.5.2.	Use with External Power Supply.....	10
3.5.3.	Atomiser Speed Control (Micromiser 12 Only).....	13
3.5.4.	Atomiser Speed Output.....	14
3.6.	Controller.....	15
3.6.1.	Mounting.....	15
3.6.2.	Electrical Connections.....	16
3.6.2.1.	Power Supply.....	16
3.6.2.2.	Atomiser.....	17
3.6.2.3.	Atomiser Speed Control Input.....	17
3.6.2.4.	Atomiser Enable Input.....	17
3.6.2.5.	Atomiser Speed Control Output.....	17
3.6.2.6.	Atomiser Run Output.....	18
3.6.2.7.	Atomiser RPM Output.....	18
3.6.2.8.	Control Ground.....	18
4.	OPERATION.....	19
4.1.	Atomiser.....	19
4.2.	Controller (Micromiser 12 Only).....	19
5.	CALIBRATION.....	20
5.1.	Flow Rate.....	20
5.2.	Spray Droplet Size.....	21
6.	MAINTENANCE.....	23
6.1.	Routine maintenance – Atomiser.....	23
6.2.	Routine maintenance – Controller.....	24
6.3.	Fault Finding.....	25
7.	PARTS LISTS.....	27
7.1.	Micromiser Atomiser.....	27
7.2.	Controller.....	27
7.3.	Cable Assembly.....	27
7.4.	Segmental Attachment.....	28

USE OF WARNING SYMBOLS

There are two safety warning symbols used throughout this handbook:



Danger related to electricity – warns of high voltage which can cause physical injury or death and/or damage to the equipment.



General danger – warns about conditions, other than those related to electricity, which can result in physical injury and/or damage to the equipment.

1. INTRODUCTION

Micronair Micromiser atomisers are designed specifically to spray a wide range of liquids in droplets of precisely controlled size. Applications include treatment of seeds and agricultural products, humidification, evaporative cooling, spraying of odour control products and any industrial processes requiring precision spray application.

Spray droplets are produced by a rotating toothed disc. Droplet size is determined by the rotational speed of the disc, which is driven by a low voltage brushless motor for maximum reliability.

Unlike hydraulic spray nozzles, the atomiser does not require a high liquid pressure to operate and there are no small internal orifices to block. This allows the atomiser to handle viscous materials and liquids with a high solids content.

The atomiser can operate at flow rates of up to 300 ml/min, with the minimum flow rate determined only by the liquid delivery system used.

The brushless motor has integrated drive electronics and requires only a 24 V DC supply to operate. A pulse output is provided for the measurement of disc speed or monitoring of atomiser performance.

The atomiser is available in two versions:

Micromiser 12 with rotational speed variable over the range of 1,500 – 12,000 RPM to produce spray droplets of 60 – 300 µm VMD. This atomiser can be used for spray application on surfaces, in industrial processes etc. The atomiser motor incorporates closed-loop speed control to ensure constant rotational speed regardless of liquid flow rate.

The Micromiser 12 can be fitted with an optional segmental attachment that restricts the spray droplets from the disc to a fan-shaped pattern for application across a band for treatment of surfaces, conveyors etc. The remaining spray liquid is collected and recycled to the supply.

Micromiser 16 with a fixed rotational speed of 15,000 – 16,000 RPM to produce small spray droplets of 45 – 60 µm VMD for humidification, evaporative cooling, application of odour control products etc.

An optional DIN rail mounted power supply and control module is available for use with the Micromiser 12 atomiser. This has a 110/240 V AC/DC input and incorporates a speed controller to enable the atomiser to be set to operate at the required speed regardless of liquid flow rate. The speed can be set either by a control on the front panel or by an external potentiometer or control input. The module has an input for an external run/stop command and provides outputs for motor status and disc rotational speed.

2. SPECIFICATION

2.1. Atomiser

Dimensions:	Length 105 mm (including atomiser disc but excluding connector), diameter 58 mm (max), 32 mm (motor housing)
Weight:	240 g
Mounting:	By two M4 tapped holes
Liquid feed connection:	Push-in fitting for 6 mm O/D rigid plastic tube
Vent connection:	Push-in fitting for 3 mm O/D rigid plastic tube
Electrical connection:	4 pin M12 sealed connector (A-coding)
Environmental protection:	IP65 (with motor vent tube connected)
Ambient temperature:	-10 – +40 °C nominal (minimum temperature must not be below freezing point of liquid being sprayed)
Input voltage:	24 V DC
Power consumption:	1 – 10 W (dependant upon disc speed and liquid flow rate)
Motor rating:	Continuous
Disc speed:	Micromiser 12: adjustable 1,500 – 12,000 RPM Micromiser 16: fixed 15,000 – 16,000 RPM
Speed output:	5 V pulse output (one pulse/disc revolution)
Spray droplet size:	Micromiser 12: 60 – 300 µm VMD Micromiser 16: 45 – 60 µm VMD (dependant upon disc speed & liquid properties)
Liquid flow rate:	0 – 300 ml/minute inlet flow

2.2. Segmental Attachment

Dimensions:	Diameter 75 mm max, length 70 mm from flange of atomiser body (excluding hose connector)
Weight:	30 g
Drain outlet connection:	Hosetail for 6 mm I/D flexible tube
Spray segment:	60° included angle
Liquid in spray segment:	25% (remainder drained from outlet)

2.3. Controller

Dimensions:	Height 75 mm, width 55 mm, depth 110 mm (excluding connector)
Weight:	300 g
Mounting:	DIN 46 227 (DIN EN 50 022) rail or by two 4 mm mounting holes in base
Environmental protection:	IP20
Ambient temperature:	-10 – +40° C (non condensing)
Input voltage:	85 – 260 V 50 – 60 Hz AC 120 – 370 V DC
Power consumption:	15 W max (dependant upon disc speed and liquid flow rate)
Atomiser speed range:	Micromiser 12 only: 1,500 – 12,000 RPM
Electrical connections:	Atomiser – 4 pin M12 connector (A polarisation) Power and control inputs/outputs – screw terminals
Control inputs:	Remote motor speed (DC voltage) Motor inhibit/enable (pull low to inhibit)
Outputs:	Motor status (NPN transistor, pulled low when running) Disc RPM (DC voltage)
Front panel:	Speed control knob LED indicators (green) for power, motor enabled and motor running

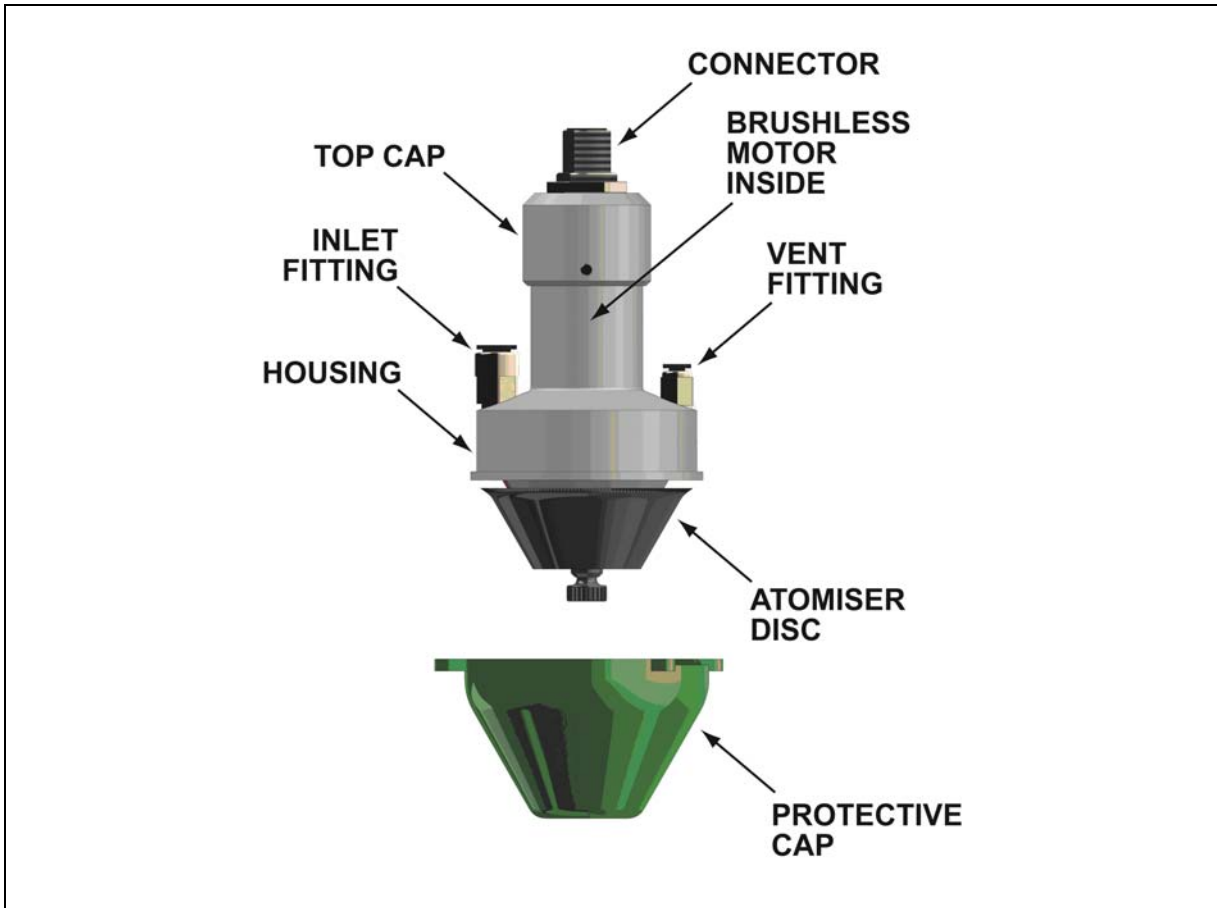

Fig 1. – Micromiser Atomiser

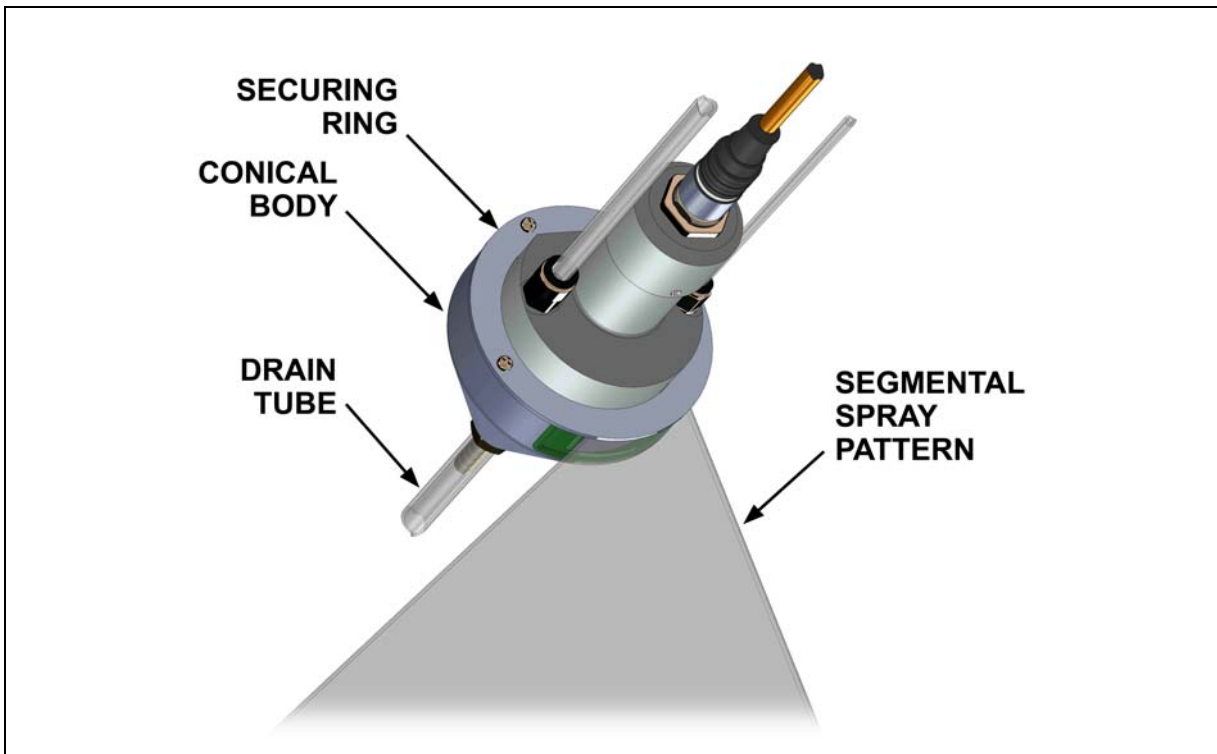

Fig 2. – Micromiser 12 with Segmental Attachment

3. INSTALLATION

3.1. Atomiser

The Micronair Micromiser atomiser has a wide range of uses and the specific details of the installation will depend upon the application and the operating environment. The following sections are provided for general guidance only.



It is the responsibility of the installer and/or end user to ensure that the installation of the atomiser and all associated wiring, pipework and equipment complies with all applicable standards and statutory requirements.



It is the responsibility of the installer and/or end user to ensure that water or other spray liquids are handled and/or treated so as to eliminate the possibility of the distribution of bacterial or other infections in spray droplets.



The atomiser must NOT be installed in an explosive atmosphere. The atomiser must NOT be used to spray liquids with a flash point of 40° C (104° F) or below or in any situation where the spray liquid or spray droplets could cause a fire, explosion or other hazard.

The atomiser must be fitted to a suitable mounting bracket supplied by the installer. The design of the bracket will be determined by the adjacent structure, but the following general points must be observed:

- The atomiser should be attached to the mounting bracket with two M4 screws in the tapped holes in the side of the atomiser housing (25 mm between hole centres) as shown in Fig. 3. M4 x 12 mm stainless steel cap head screws are supplied with the atomiser and these are suitable for a bracket with a thickness of 2 – 6 mm. If alternative screws are used these should also be stainless steel.
- The bracket must be sufficiently rigid to avoid excessive vibration when the atomiser or any nearby equipment is operating.
- The design of the installation should allow the atomiser and its rotating disc to be easily removed for cleaning and servicing.

3.1.1. Mounting – Basic Atomiser

When used without the segmental attachment the atomiser is designed to be mounted with the disc downwards and with the axis of the disc within $\pm 30^\circ$ of the vertical.



The toothed edge of the rotating disc of the atomiser is sharp and can cause serious injury if touched whilst it is rotating. The atomiser must be installed in a position where it cannot be touched or come into contact with clothing, hair etc during operation (either by mounting at a height of 3 m or more above floor level or in an enclosed space). If the atomiser is installed in an enclosed space all access doors, panels etc must be fitted with electrical interlocks to disconnect the power supply to the atomiser when opened.

The bracket and any adjoining structure should not protrude below the area shown in Fig. 3. This is to minimise contamination by spray droplets from the rotating disc.

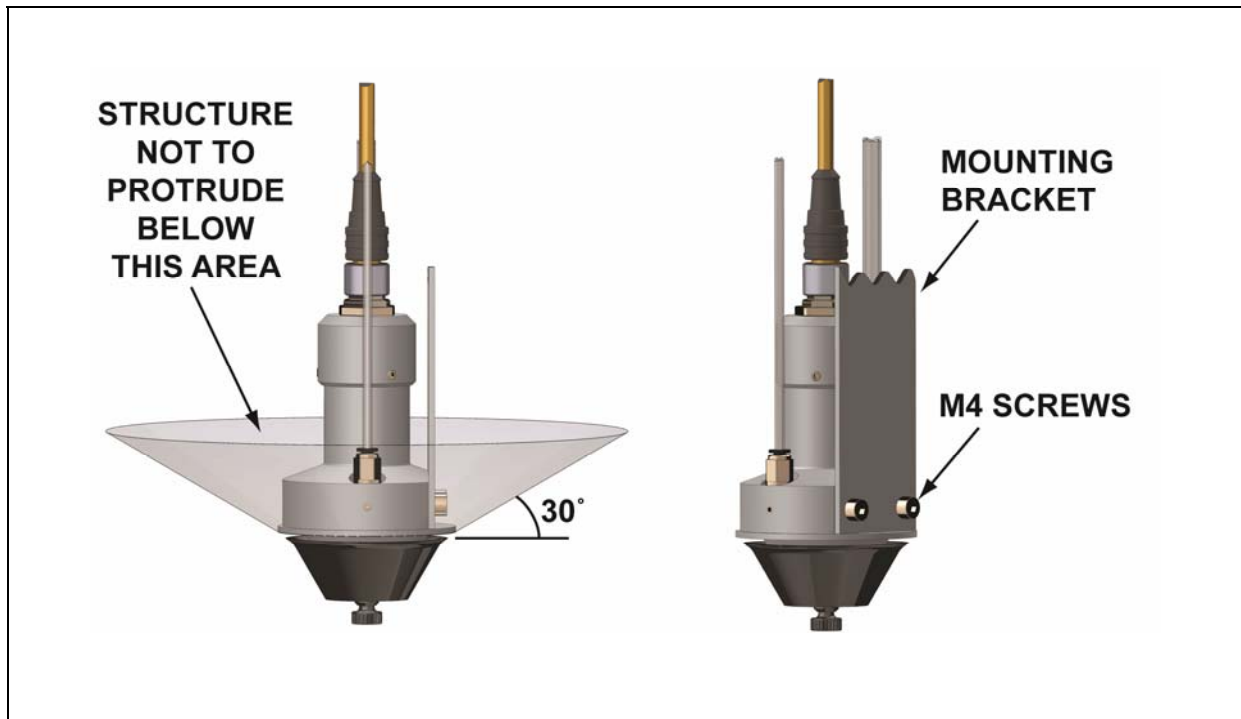

Fig. 3 – Mounting of Atomiser

3.1.2. Mounting – With Segmental Attachment

If not already fitted, the segmental attachment must be mounted on the atomiser by means of its securing ring and the three self-tapping screws supplied. The 6 mm inlet fitting and M4 securing screws must be removed from the atomiser body before fitting the securing ring and be replaced afterwards.

When used with the segmental attachment the atomiser must be mounted above the surface to be sprayed with the axis of the disc inclined at an angle of at least 45° below the horizontal as shown in Fig. 4. This is to allow spray liquid collected within the conical body to flow into the drain tube.

The segmental attachment is mounted on the body of the atomiser by means of a securing ring and three self-tapping screws. The attachment can be rotated on the atomiser after slackening the screws to adjust the trajectory of the segmental spray pattern. The screws must be re-tightened after adjustment.

The width of the band sprayed will depend upon the distance of the atomiser from the surface as measured along the trajectory of the spray droplets.

In order to ensure even spray coverage across a surface the atomiser should be mounted above a point corresponding to about 66% of the width of the spray band as viewed on the motor end of the atomiser – see Fig. 4. The segmental attachment should be rotated to achieve the correct lateral position of the spray band.

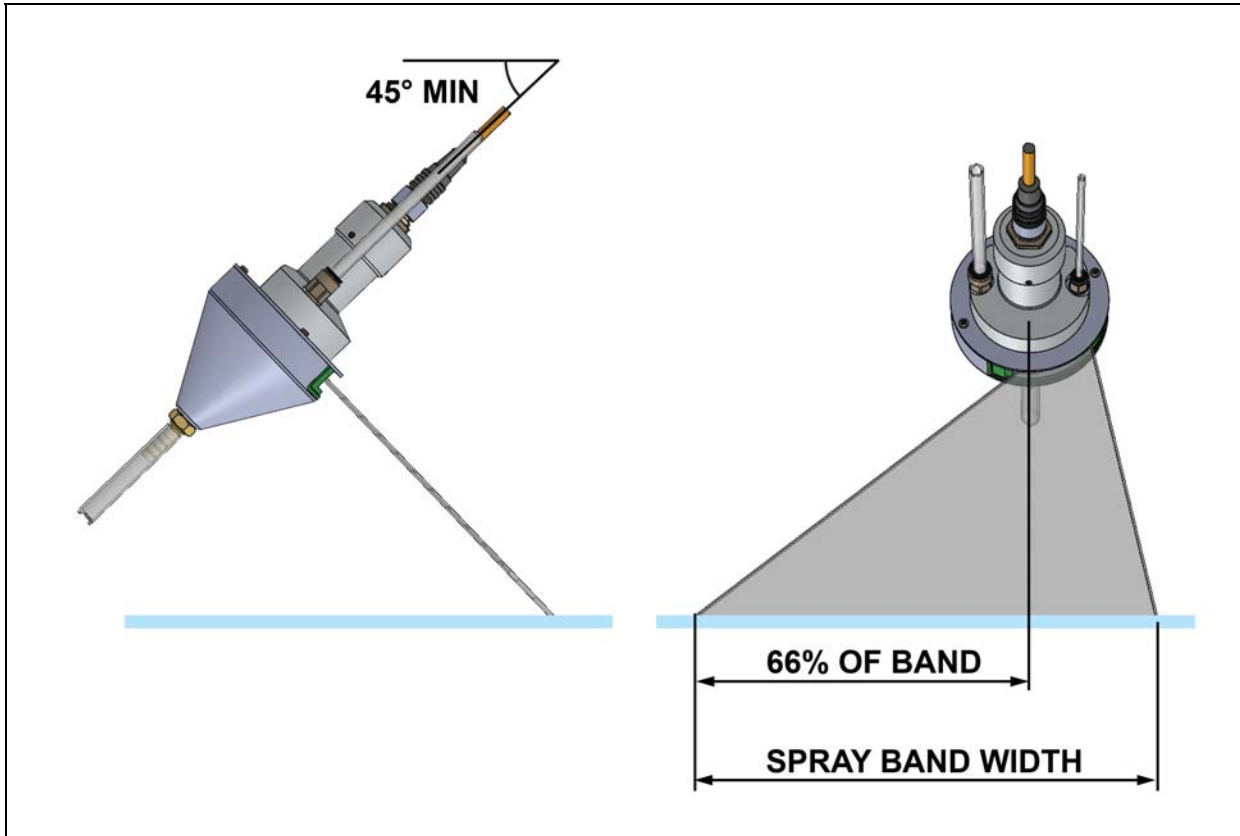

Fig. 4 – Mounting of Atomiser with Segmental Attachment

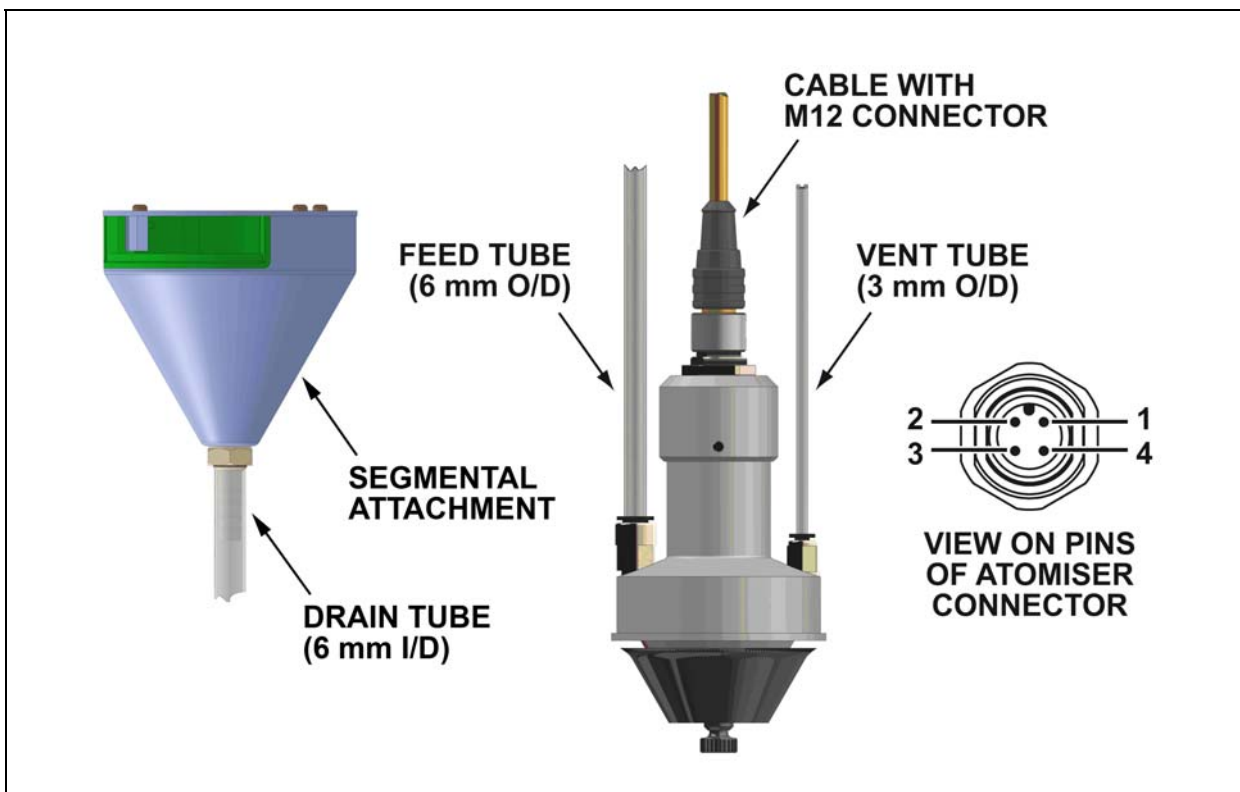
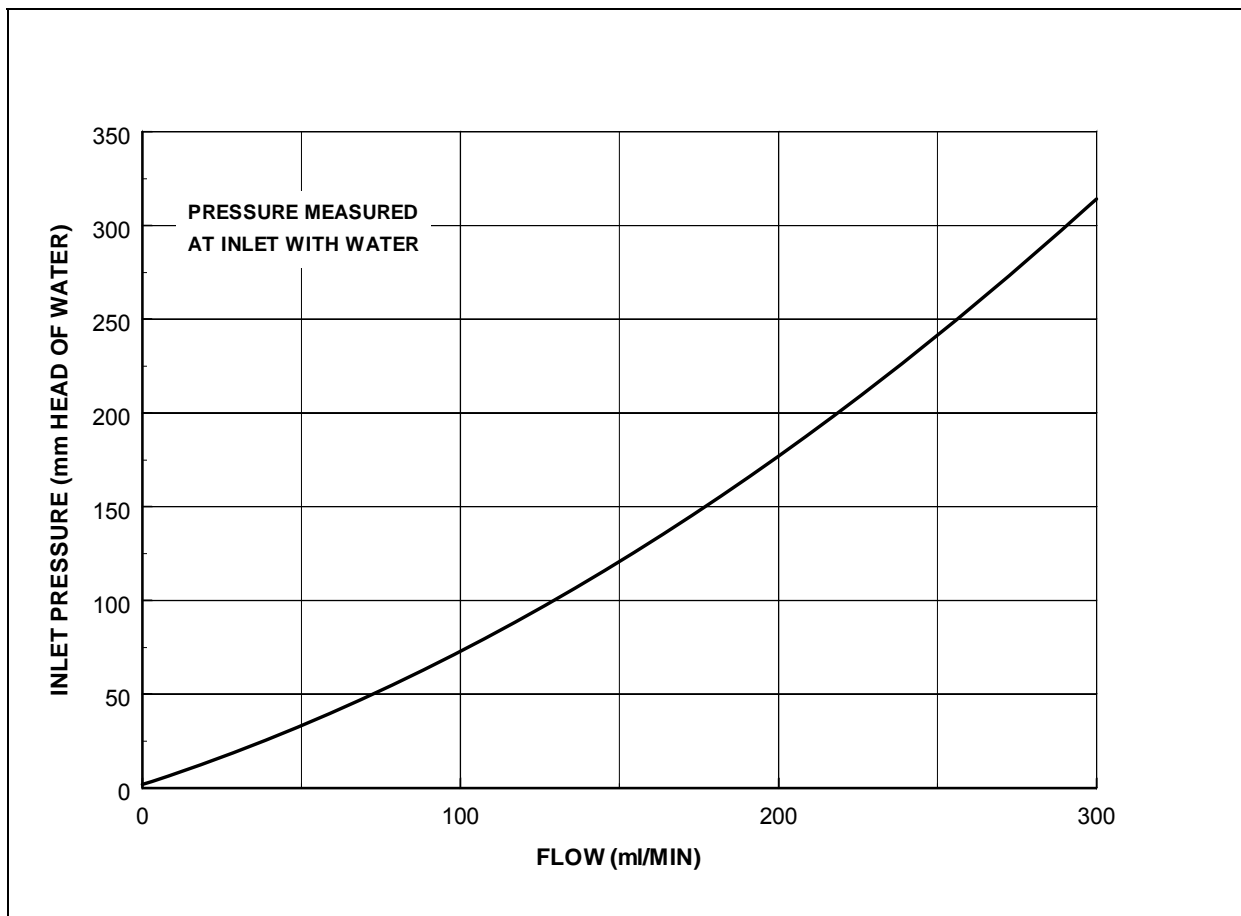

Fig. 5 – Connections to Atomiser

3.2. Liquid Feed

The liquid feed to the atomiser is by a tube connected to the inlet fitting at the top face of the housing as shown in Fig. 5. The standard fitting supplied with the atomiser is a push-fit type that accepts a 6 mm outside diameter flexible tube. If required, this fitting can be replaced with an alternative type with a M5 male thread to screw into the atomiser housing.

As there are no small orifices in the atomiser, the liquid pressure required at the atomiser inlet is very low – see Graph 1.



Graph 1 – Inlet Pressure vs Flow Rate

Liquid can be fed to the atomiser either by gravity from a header tank or by means of a pump. If a gravity feed or pressurised supply is used the installer must provide a suitable flow control (eg a fixed orifice or a needle valve). If a flow restrictor is used it is recommended that the pressure on the inlet side of the restrictor is kept as low as possible to avoid the need for a small orifice and to minimise the risk of blockage. Alternatively, a positive displacement dosing pump can be used without a flow restrictor.

3.3. Liquid Drain

If the atomiser is fitted with a segmental attachment the excess liquid collected within the conical housing drains from the 6 mm diameter hose fitting at the bottom of the cone. This liquid must be allowed to flow by gravity either back into the main reservoir or into a collecting tank from which it can be recycled.

3.4. Motor Venting

In many applications (evaporative cooling, humidification etc) the atomiser will operate in a high humidity environment. In order to avoid condensation inside the motor, the atomiser is fitted with a vent port that must be connected to a tube that can supply air from an area of low humidity (eg outside the air handling unit or other enclosure) – see Fig. 5. The standard vent fitting supplied with the atomiser is a push-fit type that accepts a 3 mm outside diameter flexible tube. If required, this fitting can be replaced with an alternative type with a M5 male thread to screw into the atomiser housing.

When operating at 5,000 RPM or above, the rotation of the atomiser disc creates a small negative pressure inside the motor housing and this is sufficient to draw air into the vent port provided that the length of the vent tube does not exceed 2 m. In this case, the tube must run upwards throughout its length so as to avoid any loops that could trap moisture – see Fig. 6.

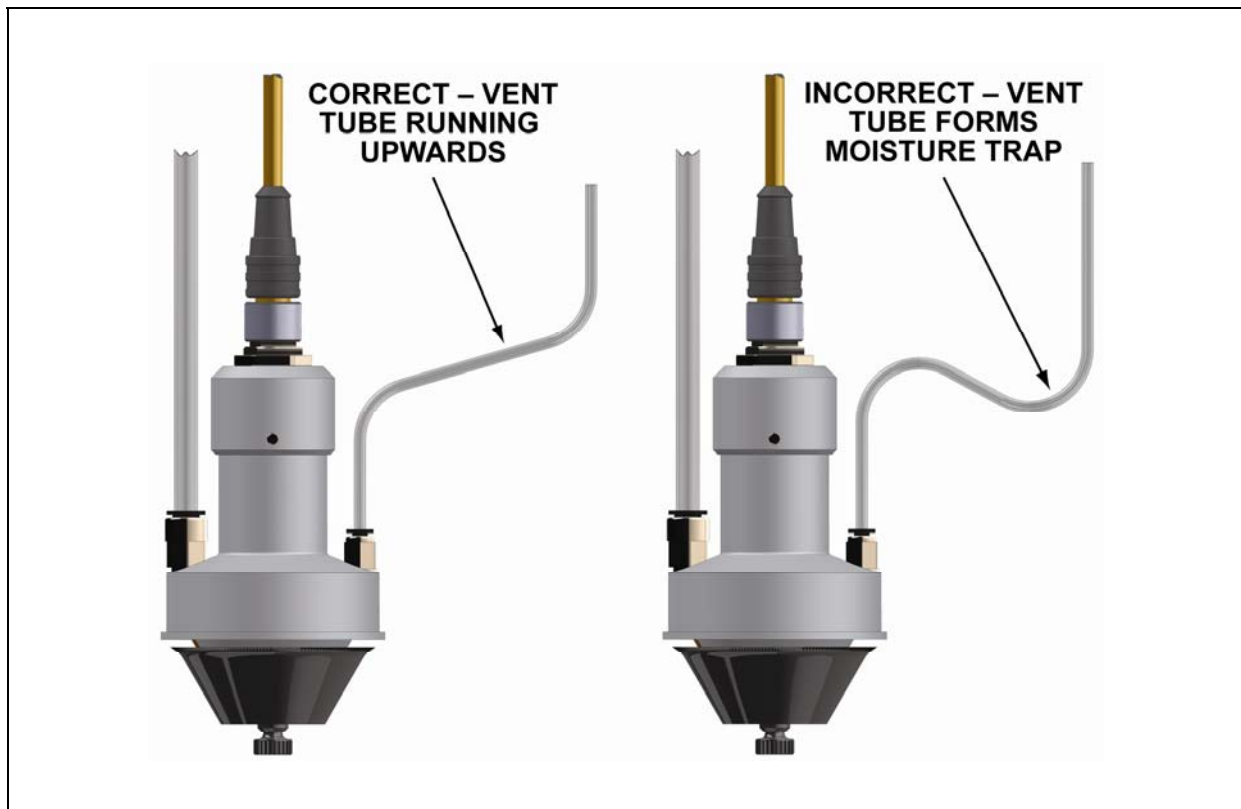

Fig. 6 – Orientation of Atomiser Vent Tube

If the atomiser is operated in a high humidity environment at less than 5,000 RPM or if it is not possible to install a vent tube leading to an area of low humidity, the vent should be purged with a supply of dry compressed air or inert gas. A suitable pressure and/or flow regulator should be provided to limit the flow rate to approximately 10 – 100 cc/min.



It is the responsibility of the installer to provide adequate venting for the atomiser. Micron Sprayers Ltd cannot accept any liability for damage to the motor resulting from condensation due to inadequate venting.

3.5. Electrical Connections

The atomiser is fitted with a sealed 4 pin male M12 connector (A-coding). Pin numbers are as shown in Fig. 5.

It is recommended that the cable with moulded connector supplied with the atomiser is used to connect it to the remote power supply or controller so as to prevent moisture ingress. If an alternative re-wireable connector is used it must be filled with non-corrosive silicone rubber compound.

The cable used to connect the atomiser to the power supply or controller should have a minimum conductor size of 0.33 mm² (22 AWG) for a length of 10 m or less or 0.5 mm² (20 AWG) for longer lengths.

3.5.1. Use with Micronair Controller

If a Micromiser 12 atomiser is to be used in conjunction with the Micronair controller (P/N EX7482), the 4 pin connector on the atomiser must be connected to the 4 pin connector on the controller. It is recommended that a ready-made cable with moulded connectors should be used. If re-wireable connectors are used, the corresponding pin numbers should be connected together (1 – 1, 2 – 2, 3 – 3 & 4 – 4) with pin assignments as shown in Fig. 5.

See section 3.6 for further details of the installation of the controller.

3.5.2. Use with External Power Supply

A Micromiser 12 atomiser can be operated from a 24 V DC power supply instead of the Micronair controller and a Micromiser 16 atomiser must always be operated from a 24 V DC supply. This supply must be provided by the installer and the minimum requirements are:

Output voltage:	24 V.
Current:	0.75 A minimum continuous.
Current limit:	Internal current limit, fuse or circuit breaker to limit fault current to 1 A maximum.
Ripple:	100 mV P/P maximum at max load.

Graph 2 shows the relationship between current consumption, atomiser rotational speed and liquid flow rate for the Micromiser 12. Graph 3 shows the relationship between current consumption and liquid flow rate for the Micromiser 16 when operated from a 24 V supply.

If a Micromiser 12 atomiser is operated from a power supply provided by the installer it is necessary to use an external variable or fixed resistor to adjust the speed of the disc. See section 3.5.2 for details.

Connections to the atomiser are as follows (see Fig. 5 for numbering of connector pins):

- Pin 1 (brown wire in standard moulded M12 cable): +24 V DC supply.
- Pin 2 (white wire in standard moulded M12 cable): speed measurement pulse output if required, must be left open circuit otherwise.
- Pin 3 (blue wire in standard moulded M12 cable): power supply ground (0 V) and ground side of speed control resistor (Micromiser 12 only).
- Pin 4 (black wire in standard moulded M12 cable): speed control resistor (Micromiser 12 only). Must be left open circuit for Micromiser 16.



Important: verify polarity before connecting the atomiser. Reverse polarity will destroy the atomiser motor.



Pin 2 MUST be left open circuit unless used for speed measurement – see section 3.5.4). Connecting this wire to ground or a supply voltage could destroy the atomiser motor.



Pin 4 MUST ONLY be connected to a resistor to control the speed of a Micromiser 12 atomiser. Connecting this wire to a supply voltage could destroy the atomiser motor. Pin 4 MUST be left open circuit for a Micromiser 16 atomiser.



It is the responsibility of the installer to ensure that the power supply is installed and connected in accordance with all applicable standards and statutory requirements. The installer is also responsible for ensuring that the complete installation (atomiser, power supply and associated wiring) complies with the applicable standards for electromagnetic compatibility (EMC).

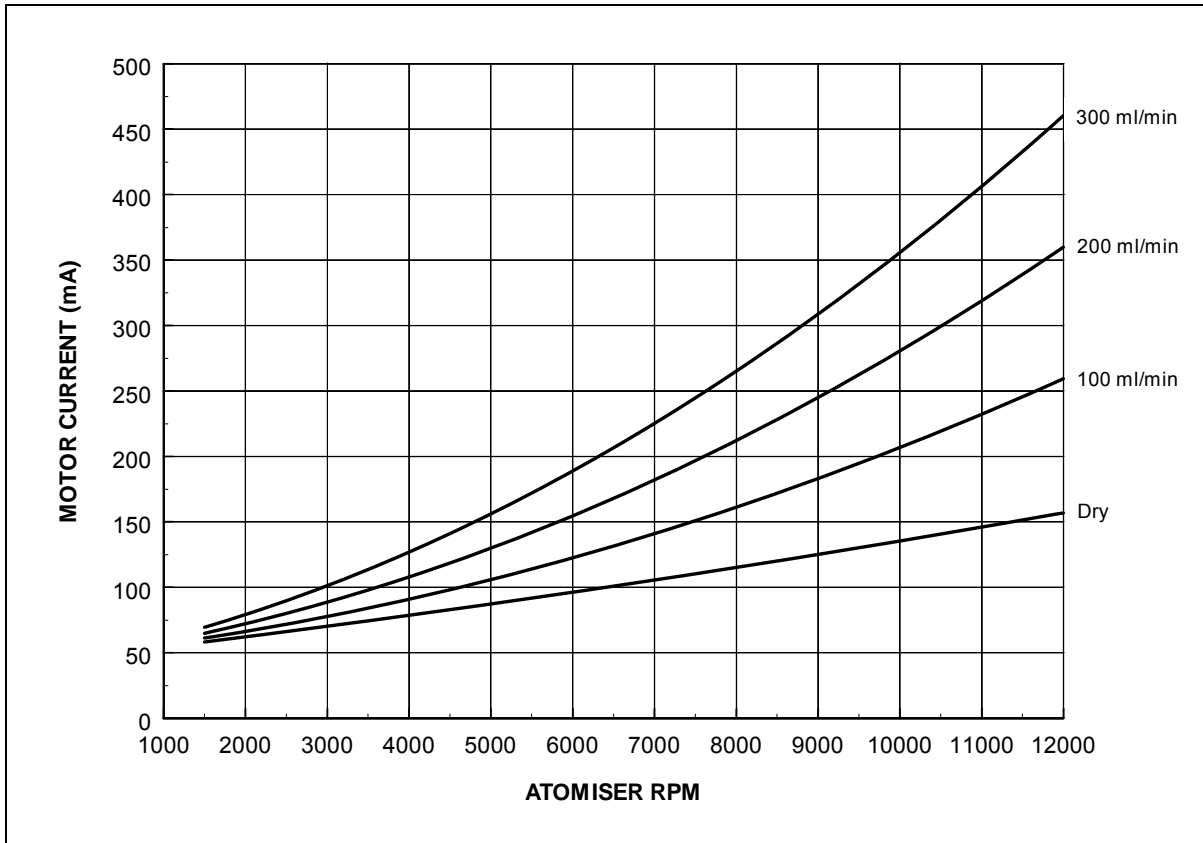

Graph 2 – Current Consumption of Micromiser 12 vs Atomiser RPM and Flow Rate

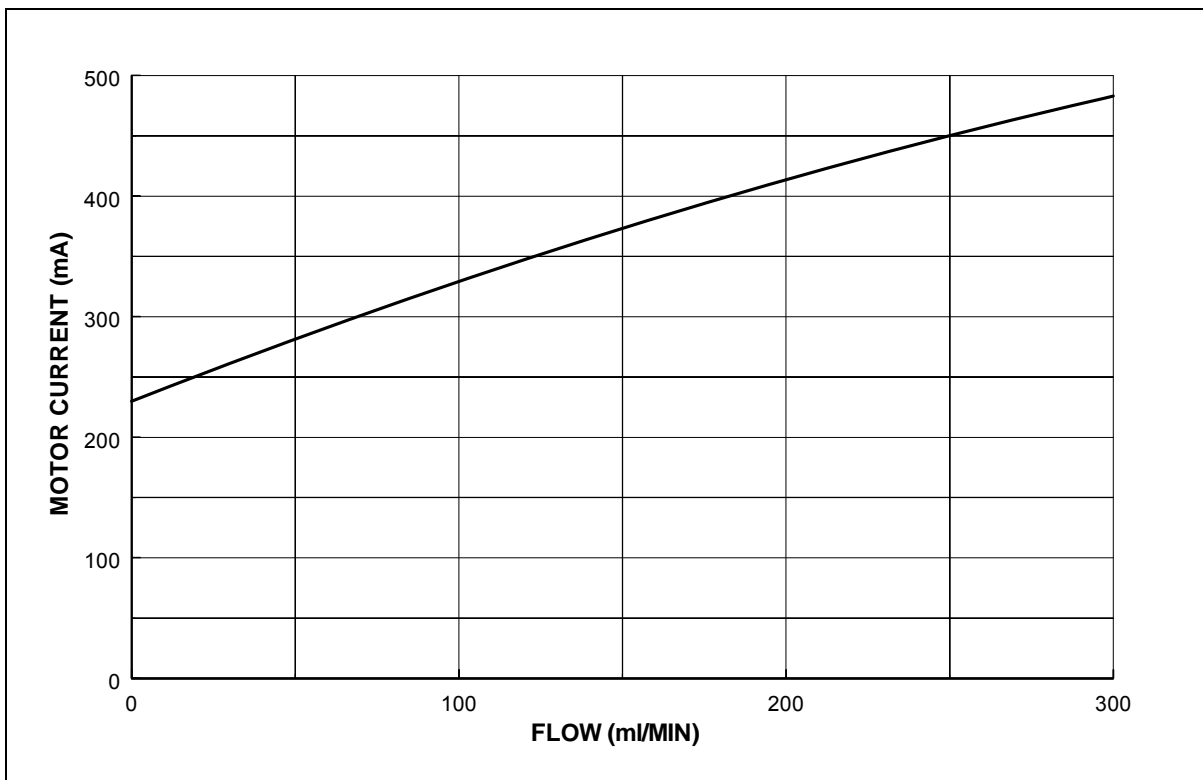

Graph 3 – Current Consumption of Micromiser 16 vs Flow Rate at 24 V Input

3.5.3. Atomiser Speed Control (Micromiser 12 Only)

The speed the Micromiser 12 atomiser is determined by the voltage on pin 4 of the motor connector. This pin is pulled up to the internal +5 V supply of the motor controller and an external resistor between pin 4 and ground forms a potential divider to set the control voltage. Fig. 7 shows a simplified schematic of the control input.

The external speed control resistor can be either an adjustable potentiometer or a fixed resistor if the atomiser is always to operate at a set speed. Graph 4 shows the relationship between atomiser RPM and speed control resistor value. It is recommended that a 10 K Ohm potentiometer is used if the atomiser is to be operated over its entire speed range.

The minimum speed of the Micromiser 12 is 1,500 RPM. This will be achieved with a control resistor value of 47 Ohms. The atomiser will not rotate if the control resistor is below 47 Ohms. It is recommended that a 47 Ohm resistor should be fitted between the lower side of the potentiometer and ground – see Fig. 7. This ensures that the atomiser runs at its minimum speed with the potentiometer set fully anti-clockwise.

The internal motor controller of the Micromiser 12 atomiser operates in closed loop mode and compensates automatically for the load of liquid on the disc. The disc speed therefore remains constant over the full range of flow rates. The disc speed can be adjusted with the atomiser running dry and will not change under load.

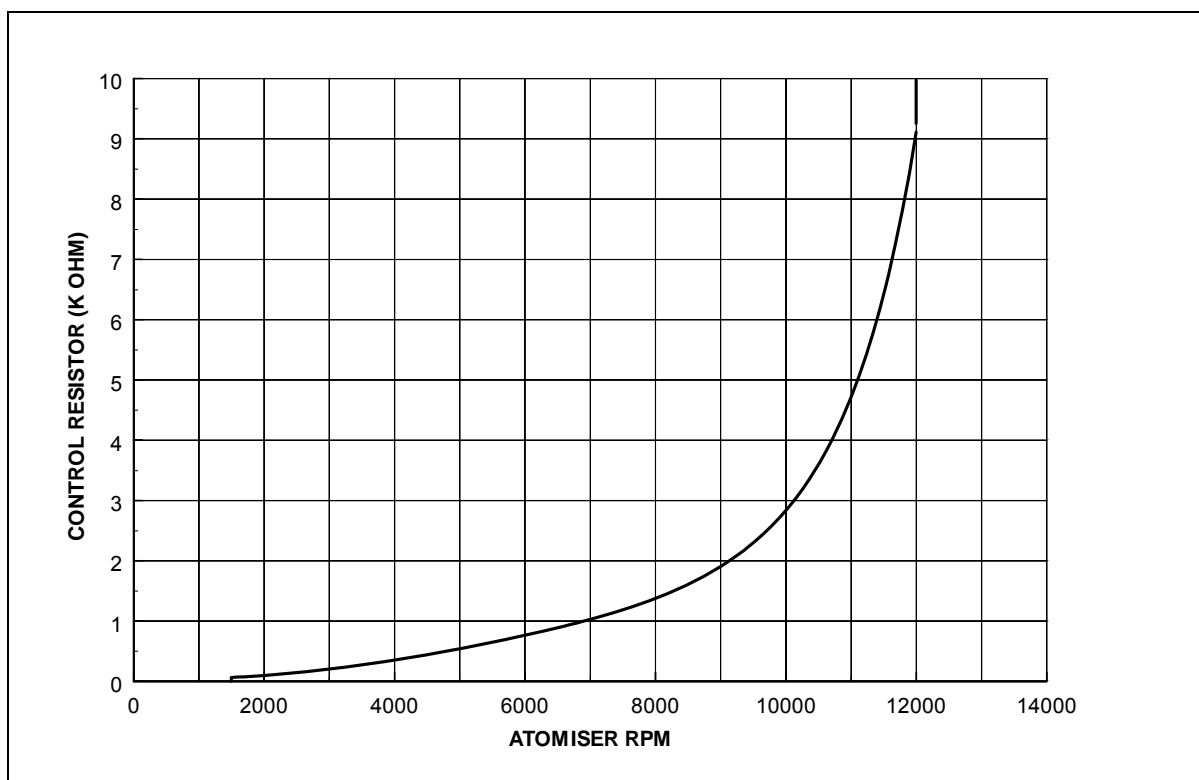

Graph 4 – Micromiser 12 Atomiser RPM vs Control Resistor Value

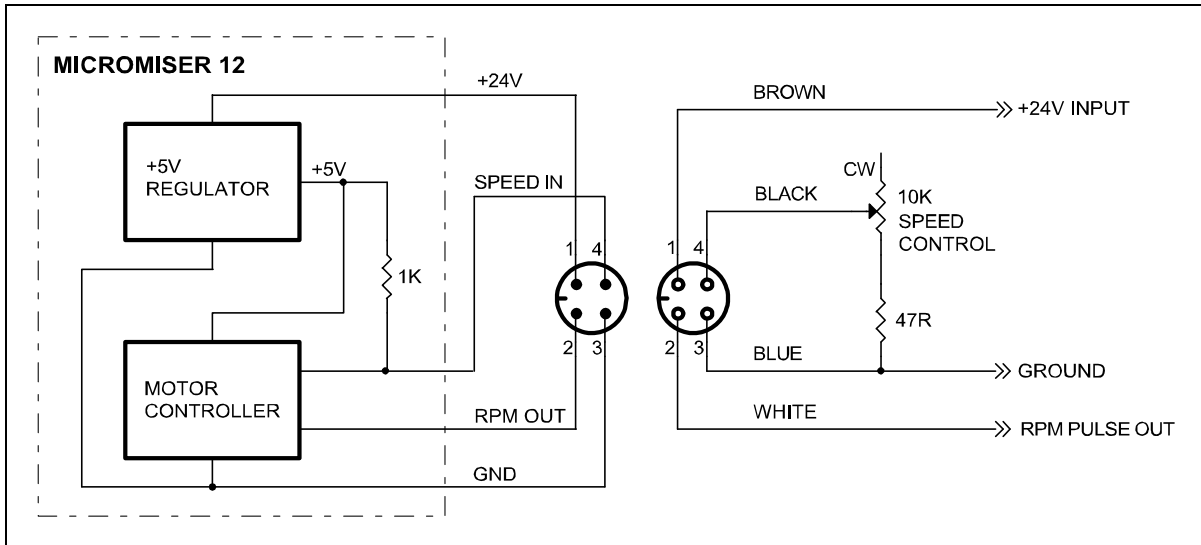

Fig. 7 – Schematic of Speed Control for Micromiser 12

3.5.4. Atomiser Speed Output

A pulse output is provided to enable the rotational speed of the atomiser to be measured without the use of an external tachometer or stroboscope on the disc.

The atomiser speed can be measured either with a portable instrument (eg a laboratory frequency counter or multimeter with a frequency function) or by a permanently installed indicator calibrated to read RPM directly.

The speed output is provided on pin 2 of the atomiser connector (white wire in standard moulded M12 connector). The specification of this output is:

Scaling:	One pulse per revolution
Pulse amplitude:	+5 V relative to ground (pin 3)
Minimum load impedance:	50 K ohm
Maximum load capacitance:	0.01 μ F



Important: connecting an instrument with a lower impedance or higher capacitance loading will impair the efficiency of the integrated motor drive circuit and could cause permanent damage.

If a multimeter or other frequency measuring instrument is used to measure the motor speed in Hz the atomiser speed (RPM) will be given by:

$$\text{Motor speed (RPM)} = \text{Frequency (Hz)} \times 60$$

3.6. Controller

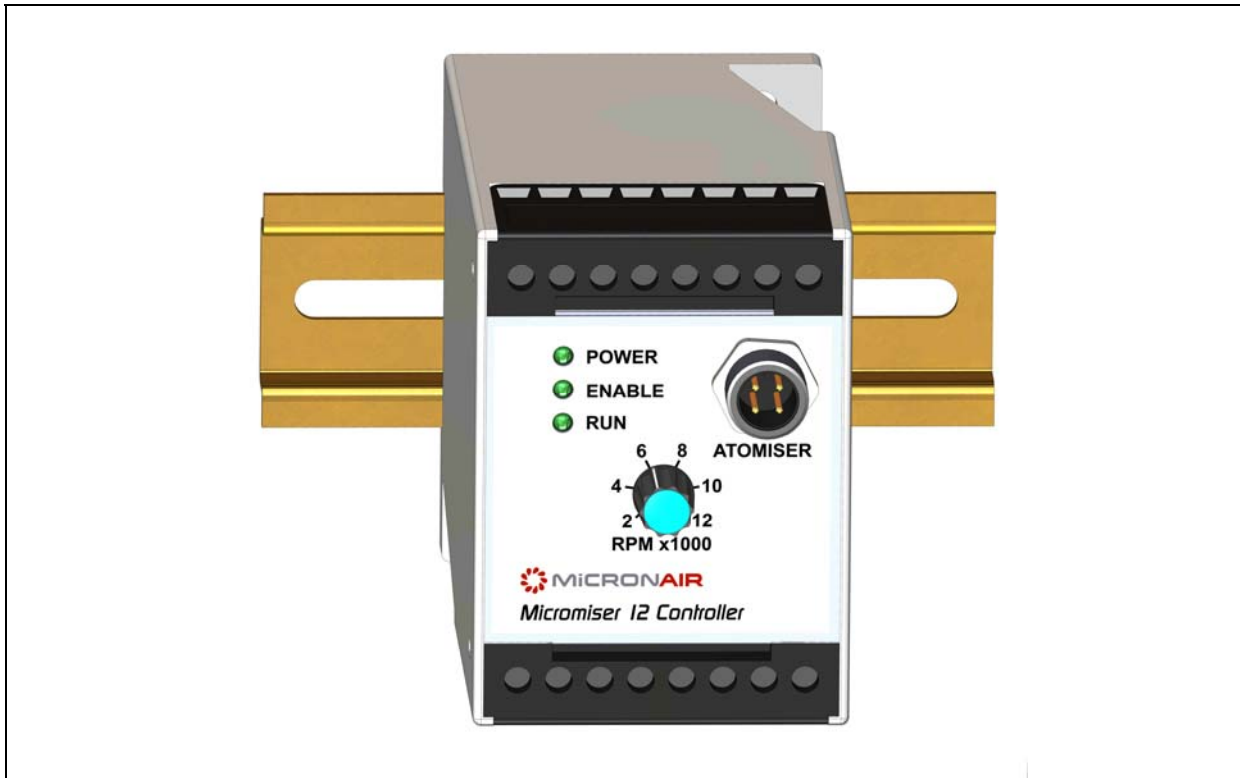

Fig. 8 – Controller Mounted on DIN Rail

The Micronair controller is designed specifically for use with the Micromiser 12 atomiser and should not be used for any other application.



It is the responsibility of the installer to ensure that the controller is installed and connected in accordance with all applicable standards and statutory requirements. The installer is also responsible for ensuring that the complete installation (atomiser, controller and associated wiring) complies with the applicable standards for electromagnetic compatibility (EMC).

3.6.1. Mounting

The controller is intended to be fitted to a standard DIN 46 277 (DIN EN 50 022) mounting rail inside a cabinet or other enclosure. If a suitable rail is not available the controller can be mounted on flat surface by two M4 screws though the holes at the corners of the base.



The housing of the controller does not provide environmental protection (IP 20 rating) and it is the responsibility of the installer to mount the controller in an enclosure that provides environmental protection and protection from electric shock appropriate to the application in which it is used.



The mains voltage terminals of the controller are protected against accidental contact to VDE 0100 Part 570, VDE 0160 Part 100 and VBG4. However, the controller must be mounted in an enclosure to restrict access to competent maintenance personnel only. If it is necessary for an operator to vary the speed of the atomiser an auxiliary speed controller potentiometer must be installed with its adjusting knob on the outside of the enclosure. See section 3.6.2.3.



The enclosure in which the controller is mounted should provide adequate ventilation and the ambient temperature inside the enclosure should not exceed 40° C at any time.

3.6.2. Electrical Connections



All electrical connections must be made with cables appropriate to the environment in which the controller is being used and the installation must comply with all applicable standards and statutory requirements.

3.6.2.1. Power Supply

The controller can be operated from 85 – 265 V AC (47 – 440 Hz) single phase or 120 – 370 V DC power supply. The power supply must be connected to the terminals on the controller as follows:

- L Live (Line) for AC supply or +ve for DC supply
- N Neutral for AC supply or –ve for DC supply
- ⏏ Protective Earth (Ground) for both AC and DC supplies



The controller must be connected to a protective earth (ground) with a minimum impedance that complies with the standards and statutory requirements applicable to the installation. The ⏏ terminal must not be left open circuit.

The controller incorporates a 2 A fuse for the protection of its internal power supply. The supply to the controller should also be protected with an external fuse (slow blow type) or circuit breaker rated at 5 A.

In installations where the atomiser is to run for prolonged periods it can be started and stopped by means of a switch or relay contacts in the Live (Line) supply connection. If the atomiser is to be stopped and started frequently it is recommended that the controller should remain connected to the power supply and the atomiser controlled by means of the Enable control input (see section 3.6.2.4).

Regardless of the means employed to control the atomiser, the power supply to the controller must be connected via a switch or circuit breaker to isolate the unit for maintenance.

3.6.2.2. Atomiser

The atomiser is connected to the 4-pin male M12 connector (A-coding) connector on the front panel of the controller. Pin assignments are as shown in Fig. 5. It is recommended that a ready-made cable with moulded connectors should be used. If re-wireable connectors are used, the corresponding pin numbers should be connected together (1 – 1, 2 – 2, 3 – 3 & 4 – 4).

See section 3.5 for details of suitable cable.

3.6.2.3. Atomiser Speed Control Input – SPD I/P Terminal

The rotational speed of the atomiser is set by an analogue voltage to this input. This voltage may be supplied either by the speed control potentiometer on the front panel or by an external potentiometer or control voltage. When using the front panel potentiometer this terminal must be connected to the Atomiser Speed Control Output – SPD O/P terminal. When using an external potentiometer the wiper must be connected to this terminal.



The voltage applied to the SPD I/P input must not exceed +12 V and must never be negative with reference to the GND terminal. Failure to observe these limits could result in damage to the controller.

3.6.2.4. Speed Control Potentiometer High – SPD HI Terminal

The speed of the atomiser can be controlled by an external potentiometer (for example on the outside of a cabinet) instead of the potentiometer on the front panel of the controller. In this case the potentiometer should have a track resistance of 10 K ohms. The end of the track corresponding to clockwise rotation of the potentiometer (maximum atomiser speed) must be connected to this terminal.

3.6.2.5. Speed Control Potentiometer Low – SPD LO Terminal

When using an external speed control potentiometer the end of the track corresponding to anti-clockwise rotation (minimum atomiser speed) must be connected to this terminal.

3.6.2.6. Atomiser Enable Input – EN I/P Terminal

The atomiser motor can be stopped and started by means of the Enable input. This terminal is active high and is pulled up to the internal 12 V supply through a 22 K ohm resistor. The atomiser will therefore run when this terminal is open circuit. The rotation of the atomiser can be stopped by pulling the Enable input low by means of a switch, relay contact or NPN transistor connected between the EN I/P and GND terminals.



The EN I/P terminal must not be connected to an external voltage. Connection to an external voltage could result in damage to the controller.



The Atomiser Enable input is intended to control the atomiser during normal operation. It must not be used to stop the atomiser prior to contact with the rotating disc. The power supply to the controller must be disconnected prior to touching the atomiser.

3.6.2.7. Atomiser Speed Control Output – SPD O/P Terminal

This terminal is connected to the wiper of the potentiometer on the front panel of the controller and provides a DC voltage to control the atomiser speed (1 V per 2000 RPM as indicated by the graduations around the potentiometer knob). When using the front panel potentiometer to control the atomiser speed this terminal must be connected to the SPD I/P terminal. If using an external control voltage this terminal must be left open circuit.

3.6.2.8. Atomiser Run Output – RUN O/P Terminal

This terminal provides an output to indicate that the atomiser is rotating at a speed of approximately 1,500 RPM or more. The output is driven by a NPN transistor and is pulled low when the atomiser speed is 1,500 RPM or more (corresponding to the green Run LED on the front panel being illuminated). This output is intended to provide an indication that the atomiser is operating normally and can be used to operate an external indicator or to provide an input to an external control or monitoring system.



The Atomiser Run output is not current limited and can sink a maximum current of 100 mA with reference to the GND terminal. The maximum externally applied voltage between the RUN O/P and GND terminals is +24 V. A higher current or voltage or a negative voltage applied to the RUN O/P terminal could result in damage to the controller.

3.6.2.9. Atomiser RPM Output – RPM O/P Terminal

This terminal provides a DC voltage proportional to the rotational speed of the atomiser disc. The output is 1 V per 2,000 RPM and can be used to drive an analogue or digital voltmeter scaled in RPM or may be used as an input to an external control or monitoring system.



The Atomiser RPM output is not current limited and a short circuit between the RPM O/P and GND terminals could result in damage to the controller. The impedance of a load connected to the RPM O/P terminal should be 5 K ohms or more for maximum accuracy of the reading.

3.6.2.10. Control Ground – GND Terminal

This terminal is connected to the ground (0 V) rail of the controller electronics and provides the reference for all low voltage controller inputs and outputs. The GND terminal is not internally connected to the mains ⚡ terminal. It is, however, important that this terminal should be connected to a protective earth (ground). If the controller is used in conjunction with an external control or monitoring system the GND terminal should be connected to the protective earth (ground) of that system so as to avoid ground loops. Otherwise, it should be connected to the local protective earth (ground) by linking it to the mains ⚡ terminal.



The GND terminal must always be connected to a protective earth (ground). Leaving this terminal open circuit could result in hazardous voltages appearing on the control input or output terminals.

4. OPERATION

4.1. Atomiser

The atomiser is provided with a clip-on plastic protective cap. This must be removed before operation and should be re-fitted if the atomiser is not to be used for a prolonged time. The cap is not required for a Micromiser 12 atomiser with a segmental attachment.

The atomiser disc must be running at its required speed before the liquid flow commences. The atomiser motor can take up to two seconds to reach its final speed so there should be a delay of a minimum of two seconds between starting the motor and starting the liquid feed to the atomiser.

The liquid flow to the atomiser must be stopped before the motor is stopped. The time for the liquid flow to cease will depend upon the diameter, length and orientation of the feed tube. There must be a sufficient delay between stopping the liquid flow and stopping the atomiser to allow the feed tube to empty completely.



The liquid flow to the atomiser should not exceed 300 ml/min. Operation at a higher flow rate could result in damage to the atomiser motor.

In cases where the atomiser motor housing is purged with dry air or gas (see section 3.1.4), the air or gas flow must continue for as long as the humidity of the atmosphere surrounding the atomiser remains high.

4.2. Controller (Micromiser 12 Only)

The controller may either be used as a stand-alone unit or it may be incorporated in a more sophisticated control and monitoring system provided by the customer. This section describes the controller as a stand-alone unit.

The rotational speed of the atomiser is set by the potentiometer knob on the front panel of the controller. The graduations around the control knob show the approximate atomiser speed (RPM x 1000). The atomiser speed should be set by adjusting the control knob before switching on the power supply to the controller.

When power is supplied to the controller the atomiser motor will accelerate to the speed set by the control knob.

If necessary, the atomiser speed can be checked by connecting a voltmeter between the RPM O and GND terminals. The voltmeter will read 1 V per 2,000 RPM (ie 4 V corresponds to 8,000 RPM).

When liquid is fed to the atomiser the motor controller of the Micromiser 12 maintains a constant rotational speed regardless of the load of the liquid on the atomiser disc.



The liquid flow to the atomiser should not exceed 300 ml/min. Operation at a higher flow rate could result in damage to the controller.

The front panel of the controller has three green LED indicators. The functions of these are:

- | | |
|--------|------------------------------------------------------------------------------------------------------------------------------------------------------------------------------------------------------------------------------------------------------------------------|
| POWER | The controller is connected to a power source and the internal power supply is operating normally. |
| ENABLE | The atomiser motor speed controller is enabled and the atomiser should be rotating. This is the default condition, but the controller may be disabled (motor stopped) by grounding the Enable input (EN I terminal). In this case the Enable LED will be extinguished. |
| RUN | The atomiser motor is running at 2,000 RPM or more. This indicates normal operation. |

When used as a stand-alone unit without an external Enable input, the normal condition is for all three green LEDs to be illuminated after power is supplied to the controller. There will, however, be a short delay whilst the atomiser motor accelerates and before the Run LED illuminates.

5. CALIBRATION

For correct operation, both the liquid flow rate and the spray droplet size must be adjusted according to the requirements of the application.

5.1. Flow rate

The flow of liquid to the atomiser must be controlled by a valve, metering pump etc provided by the installer. See section 3.2 for further details.

When fitted with a segmental attachment approximately 25% of the liquid fed to the atomiser is sprayed and the remainder is collected within the conical housing and recycled via the drain tube. The flow to the atomiser must not exceed 300 ml/min so the maximum amount of liquid sprayed is approximately 75 ml/min.

5.2. Spray Droplet Size

The diameter of the spray droplets produced by the atomiser disc is determined by the rotational speed of the disc, the liquid flow rate and the physical properties of the spray liquid.

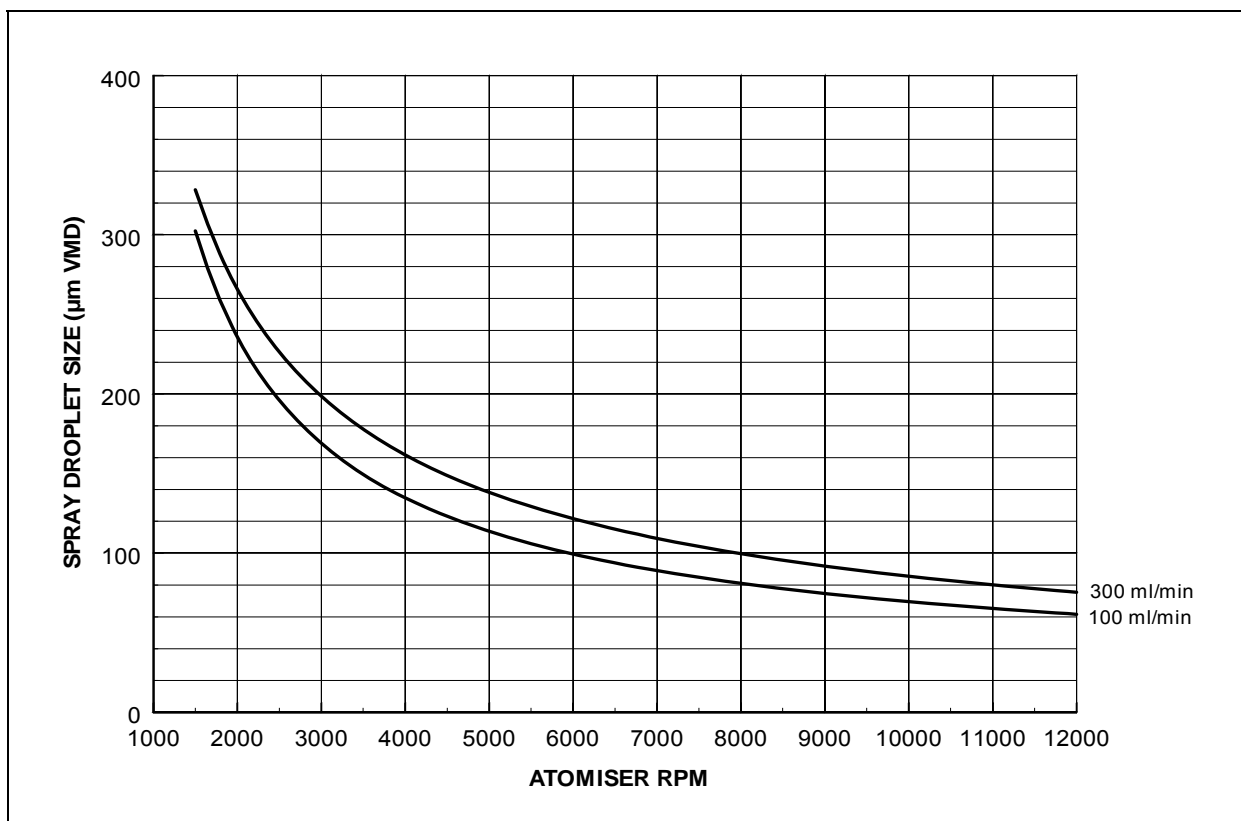

Graph 4 – Spray Droplet Size vs Atomiser RPM for Micromiser 12

Graph 4 shows the measured VMD (Volume Median Diameter) of spray droplets from the Micromiser 12 at rotational speeds of 1,500 – 12,000 RPM when spraying plain water. Graph 5 shows the relationship between measured VMD (Volume Median Diameter) of spray droplets and liquid flow rate from the Micromiser 16 when operated from a 24 V supply. These graphs are intended as a guide only as the droplet size is influenced by the physical properties of the liquid being sprayed. In general the addition of a surfactant to reduce surface tension will reduce droplet size by up to 15%. The droplet size when spraying formulations based on light oils will be about 15 – 20% smaller than shown.

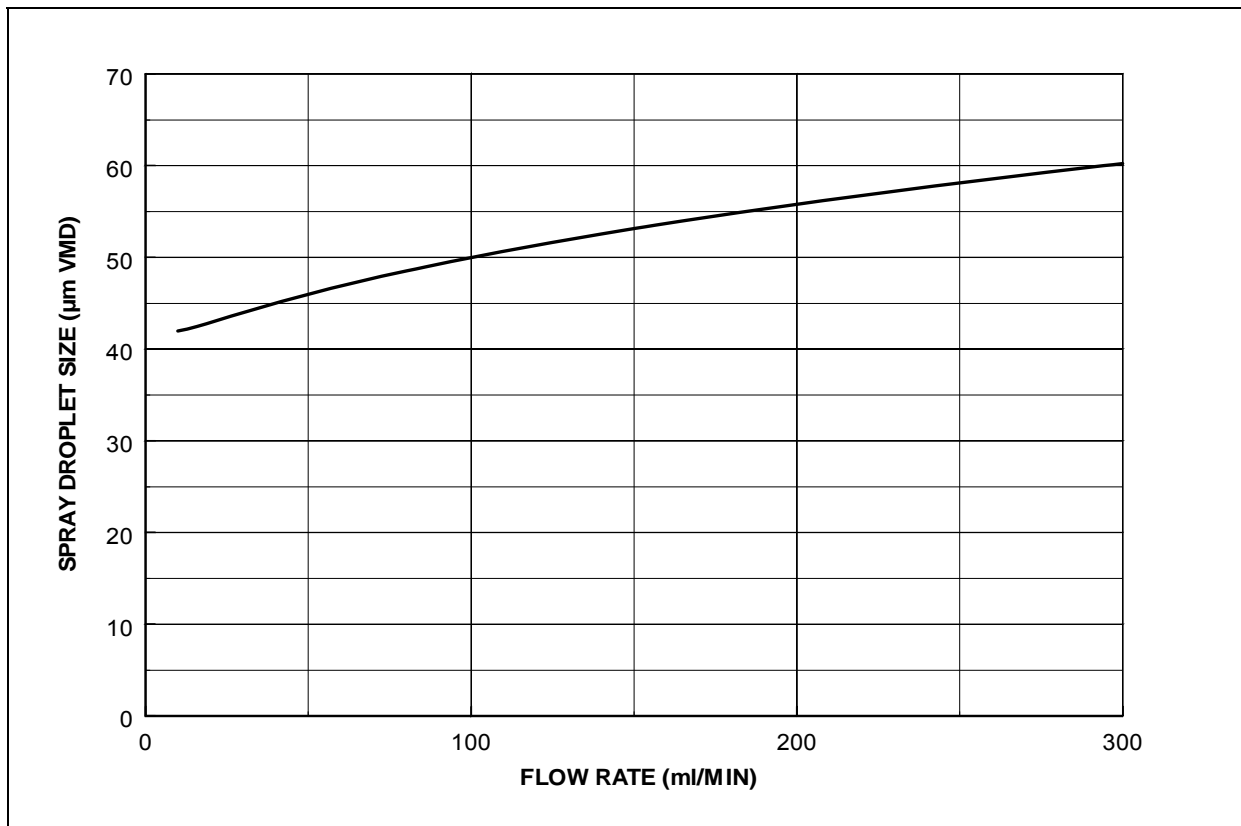

Graph 5 – Spray Droplet Size vs Flow Rate for Micromiser 16 with 24 V Supply

When using a Micromiser 12 atomiser with the Micronair controller, the required atomiser rotational speed is obtained by adjusting the control knob on the front panel

When using a Micromiser 12 atomiser with a DC power supply provided by the user the atomiser speed must be set by an external control resistor or potentiometer as described in section 3.5.3.

The Micromiser 16 atomiser is intended to operate only at its maximum speed to produce the smallest possible spray droplets. It must be used with a 24 V DC power supply and the droplet size will be as shown in Graph 5.

Note that the rotational speed is influenced by liquid flow rate and the supply voltage should be determined from the appropriate line on the graph.

6. MAINTENANCE

6.1. Routine Maintenance – Atomiser

The rotating disc of the atomiser must be kept clean at all times. Contamination of the grooves on the inner surface of the disc or of the teeth on the periphery will result in poorly controlled spray droplet size and can cause vibration.

The procedure to clean the atomiser disc is as follows:

1. Disconnect power from the atomiser or the atomiser controller.
2. Whilst holding the disc with one hand, use the other to unscrew the knurled knob of the locking collet at the bottom of the disc by about four turns.
3. Pull on the knurled knob to slide the disc off the motor shaft.
4. Immerse the disc in water or a suitable solvent for the liquid that had been sprayed and remove any residue by brushing along the grooves and between the teeth with a soft brush. Do not use a metal or other hard brush as this could damage the disc.
5. Dry the disc with a soft lint-free cloth or compressed air.
6. Inspect the teeth of the disc. If these are worn or damaged the disc should be replaced. The disc is a consumable item and replacements are available from Micron Sprayers Ltd, part number CBP3324.
7. Replace the disc on the motor shaft and slide it on as far as possible.
8. Hold the disc in one hand whilst simultaneously pushing it towards the atomiser body and tightening the knurled knob with the other. The knob should be finger tight, but do not over-tighten with pliers etc.
9. If the atomiser is not to be used immediately, fit the plastic protective cap over the disc.

Liquid is fed to the atomiser disc through a feed nozzle. If this nozzle should become blocked, the procedure to clean it is as follows:

1. Disconnect power from the atomiser or the atomiser controller.
2. Remove the atomiser disc as described above.
3. Using a 5 mm A/F socket or box spanner (wrench), unscrew the feed nozzle from the housing.
4. Immerse the nozzle in water or a suitable solvent for the liquid that had been sprayed and remove any blockage or residue by inserting a piece of wire into the bore of the nozzle
5. Dry the nozzle with a soft cloth or compressed air.
6. If necessary, remove the liquid feed tube from the atomiser and remove any residue or blockage from the hole through the housing.
7. Replace the feed nozzle in the housing.
8. Replace the atomiser disc as described above

9. The outside surfaces of the atomiser can be cleaned with a cloth moistened with water or a suitable solvent for the liquid that had been sprayed.



Aiming a jet of liquid at the underside of the feed body with the disc removed will contaminate the motor bearings and will result in premature failure of the motor.

6.2. Routine Maintenance – Controller

The atomiser controller does not require any regular maintenance.

6.3. Fault Finding

Problem	Possible Cause	Action
No liquid flow from atomiser	Blocked feed nozzle	Remove feed nozzle and clean
	Blocked or defective flow control valve or pump	Remove feed tube from fitting on atomiser and check flow rate; clean or repair valve or pump
Liquid drips from flange of atomiser feed body	Excessive flow rate	Reduce the liquid flow rate to 300 ml/min or less
	Contaminated or damaged disc	Clean disc or replace if damaged
Disc does not rotate	Faulty power supply, cable or connector	Remove connector from atomiser and check voltage between pins 1 and 3 of cable connector; locate fault and repair
	Debris between edge of disc and feed body or alongside feed nozzle	Check disc for free rotation, remove disc and clean as necessary
	Defective atomiser motor	Replace motor assembly or return atomiser to Micron Sprayers Ltd for repair
Atomiser vibrates whilst operating	Contaminated or damaged atomiser disc	Clean disc or replace if damaged
Green power LED on controller does not illuminate	No supply to controller	Check voltage between L and N terminals, locate fault and repair
	Internal fuse blown	Return controller to Micron Sprayers Ltd for repair
Atomiser runs at maximum speed when connected to controller and speed cannot be adjusted with control potentiometer	Link between SPD I and SPD O terminals not in place	Fit link
Green RUN LED not illuminated when controller supplied with power and enabled	Atomiser not running above minimum speed	Check disc for free rotation and remove obstructions as necessary
		Check for excessive liquid flow rate and reduce to 300 ml/min max

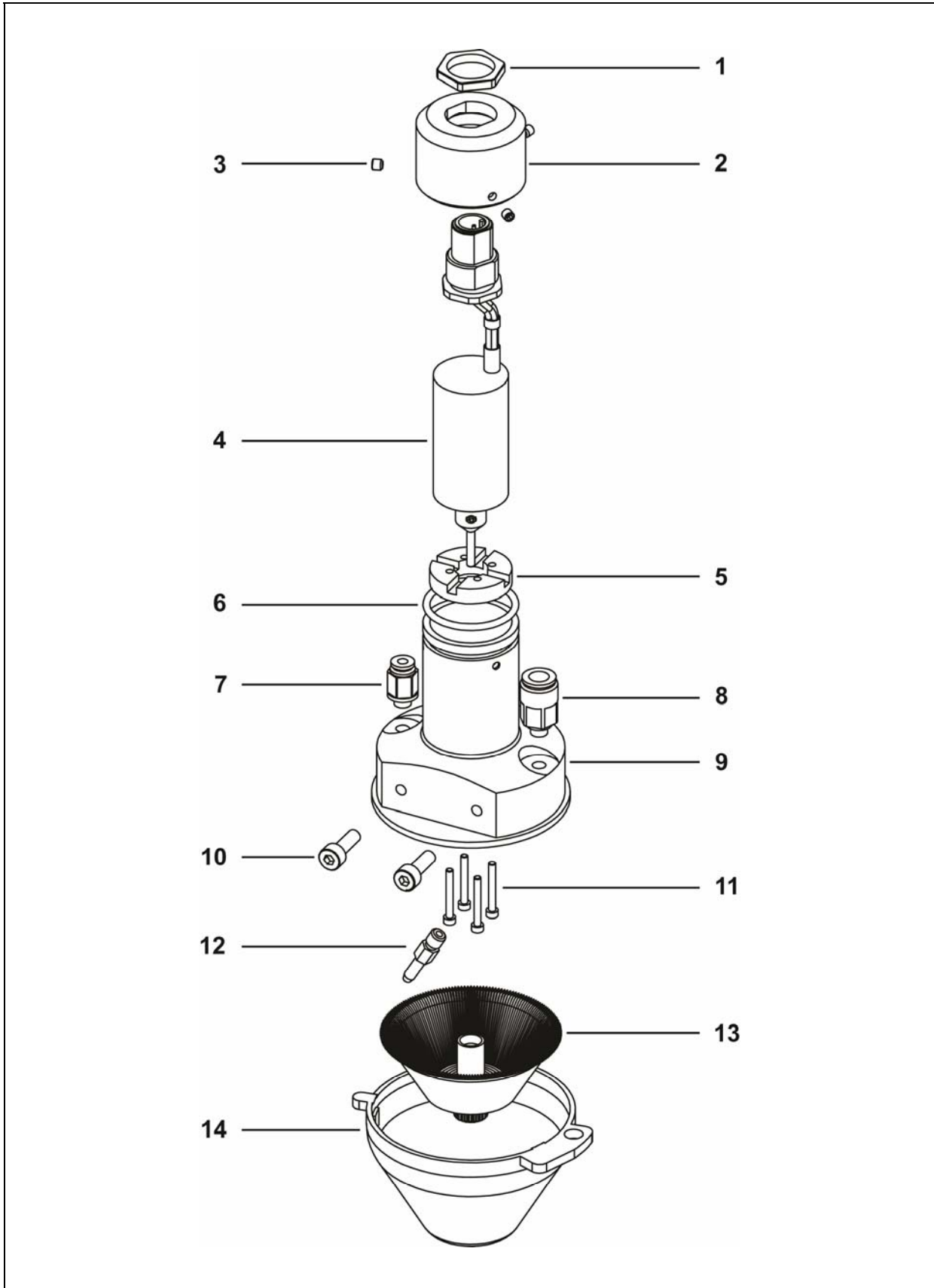

Fig. 9 – Components of Micromiser Atomiser

7. PARTS LIST

7.1. Micromiser Atomiser

Complete assembly: Micromiser 12: EX7464
 Micromiser 16: EX7465

Item	Part No	Description	Qty	Notes
1		Nut, connector retaining	1	Supplied with item 4
2	EX7167	Top cap	1	
3	CBP3319	Grub screw, M3 x 3	4	
4	EX7466	Motor assy, Micromiser 12	1	Includes connector
4	EX7467	Motor asy, Micromiser 16	1	Includes connector
5	EX7168	Spacer disc	1	
6	CBP3320	O-ring	1	
7	CBP3321	Tube fitting, 3mm	1	
8	CBP3322	Tube fitting, 6 mm	1	
9	EX7166	Housing	1	
10	CBP3323	Cap screw, M4 x 12	2	
11	CBP3316	Cap screw, M2 x 16	4	
12	CBP3325	Feed nozzle	1	2 mm bore
13	CBP3324	Atomiser disc	1	
14	EX7199	Protective cap	1	

7.2. Controller

For Micromiser 12: EX7482

Note that there are no user serviceable parts in the atomiser controller and individual spare parts are not available.

7.3. Cable Assembly with Moulded M12 Connector

Cable, 22 AWG x 2 m: CBP3430

7.4. Segmental Attachment

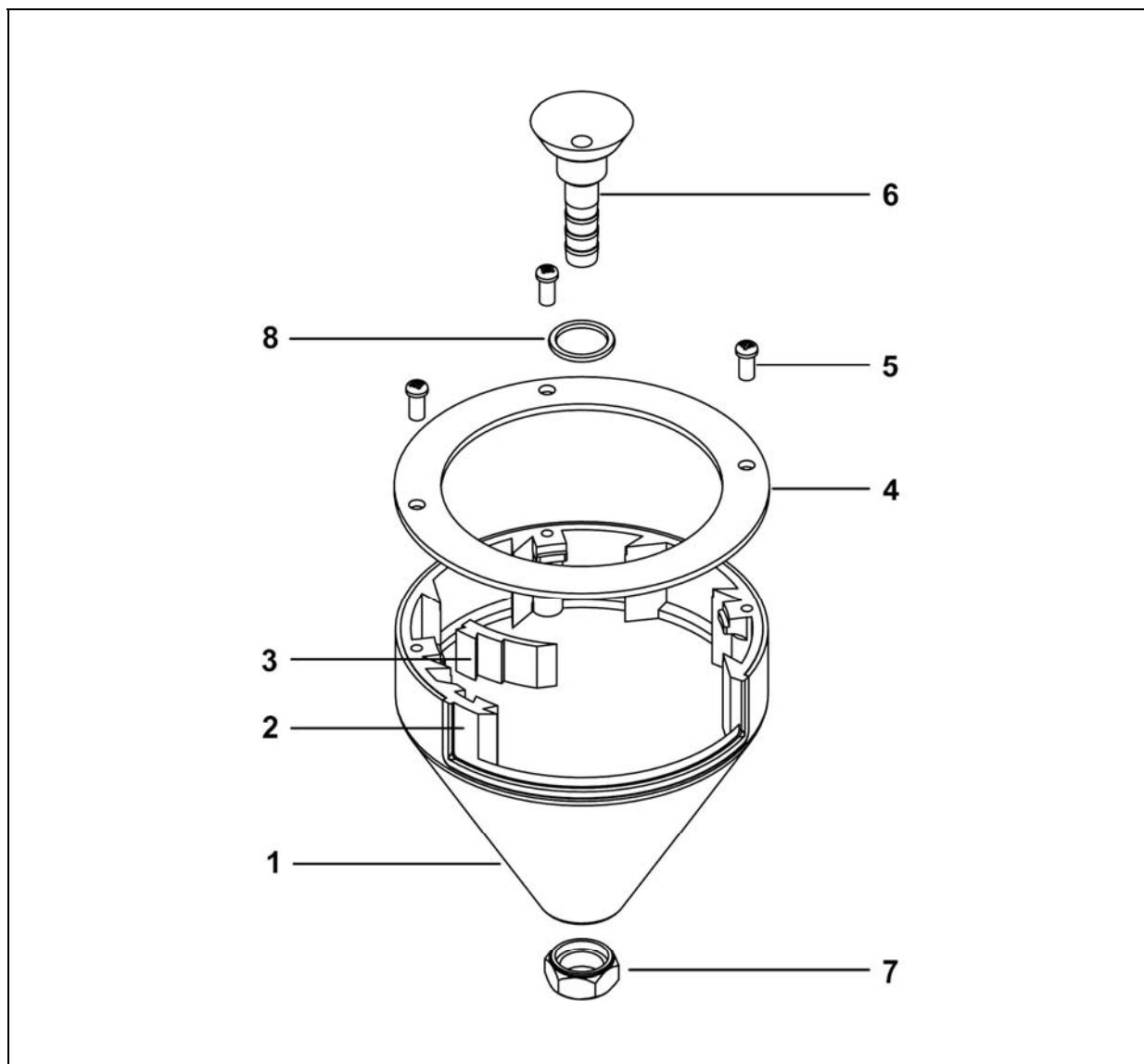

Fig. 10 – Components of Segmental Attachment

Complete assembly: EX7449

Item	Part No	Description	Qty	Notes
1	EX7450	Cone	1	} Items 1 & 2 } supplied together
2	EX7452	Catcher ring	1	
3	4911	Catcher lip	1	
4	EX7451	Securing ring	1	
5	5027	Screw, self-tapping	3	
6	EX7453	Outlet fitting	1	
7	EX7454	Nut, outlet fitting	1	
8	CBP3868	O-ring	1	

Notes

Micronair is the registered trademark of Micron Sprayers Limited, Bromyard, United Kingdom.

Every care has been taken in the design of this equipment and the preparation of this Handbook. However, Micron Sprayers Limited cannot accept responsibility for errors or the consequences thereof. The user must satisfy himself that the equipment is suited to his needs, is performing according to his requirements and that all statutory requirements and regulations are being complied with.