

MICRONAIR

AU8000 SPRAYER

Operator's Handbook and Parts Catalogue

Micron Sprayers Limited
Bromyard Industrial Estate
Bromyard
Herefordshire HR7 4HS
United Kingdom

Tel: (01885) 482397
+44 1885 482397
Fax: (01885) 483043
+44 1885 483043
E-mail: micron@micron.co.uk
Web site: www.micron.co.uk

Iss 14
05/12

TABLE OF CONTENTS

1. INTRODUCTION	1
2. SPECIFICATION	1
3. ASSEMBLY	2
4. OPERATION	3
4.1 Operation of Standard Sprayer	3
4.2 Operation of Sprayer with Optional Boost Pump.....	5
5. HEALTH AND SAFETY	7
6. CALIBRATION.....	8
6.1 Output Rate of Chemical.....	8
6.2 Adjustment of Droplet Size.....	12
7. MAINTENANCE	14
7.1 Knapsack Mistblower – Routine Maintenance	14
7.2 Possible Engine Faults and Remedies.....	14
7.3 Maintenance of Sprayhead	16
8. PARTS LISTS.....	18
8.1 AU8000 Sprayhead.....	18
8.2 AU8000 Atomiser	20
9. CONVERSION FACTORS	22

1. INTRODUCTION

The AU8000 Sprayer consists of a Micronair AU8000 sprayhead mounted on a knapsack mistblower.

The sprayhead provides a narrow, easily controlled spectrum of spray droplets to ensure an even distribution of product with a minimum of wastage. Air from the mistblower rotates the atomiser and is then directed into the airstream which carries the spray safely away from the operator and ensures maximum swath width and penetration of foliage.

The AU8000 sprayer is intended for use in agriculture, public health spraying, migratory pest control (locust, armyworm etc.) and in any other application where a safe, effective, portable sprayer is required. It can be used with conventional water-based chemicals (both solutions and solids in suspension) and with specialised ULV formulations. The unit is supplied with easily interchangeable restrictors for quick and easy calibration of output rate for all chemicals and application techniques.

Regardless of chemical type or application rate, the AU8000 sprayhead ensures optimum coverage of the target with a minimum wastage of chemical due to incorrectly sized droplets or run-off.

The AU8000 sprayhead is also available separately as a conversion kit for use with an existing mistblower. For satisfactory operation, the air output from the mistblower must be as shown in the specification below.

2. SPECIFICATION

AU8000 Sprayhead

Length:	30 cm
Diameter:	15 cm
Weight:	1.5 Kg
Air inlet tube dia:	65 mm
Chemical flow rate:	0.02 – 1.20 litres/min
Spray droplet size:	Adjustable 40 – 200 microns VMD subject to formulation used

Tank and Blower

Chemical tank capacity:	17 litres max
Weight (empty):	10.7 Kg
Engine:	77 cc 5 HP (3.6 KW) 2-stroke
Fuel tank capacity:	2 litres
Fuel consumption:	2 litres/hour approx
Blower output:	20 m ³ /min
Air velocity:	125 m/sec at outlet

3. ASSEMBLY

These instructions apply both to AU8000 sprayheads supplied as part of a complete sprayer and to sprayheads supplied as conversion kits. The steps with numbers in square brackets [] refer to conversion kits ONLY and should be disregarded when assembling a sprayer supplied complete. There may be some minor differences when installing conversion kits on some models of sprayer. Parts are identified by their reference number in Fig. 5.

- [1.] Ensure that the mistblower is empty, clean and in good running order.
- [2.] Disconnect the chemical feed hose from any existing on/off valve or flow regulator. Leave the feed hose connected to the chemical tank.
- [3.] Remove the original spray nozzle and outlet, leaving only the flexible air duct attached to the blower.
4. Insert one end of the rigid air tube (19) into the inlet of the sprayhead so that 40 mm of tube is inside the casing.
5. Slacken both clamping screws of the handle and valve assembly (13). Slide the handle over the air tube with the handle angled towards the sprayhead. Position the handle with one clamp over the slotted inlet of the sprayhead casing and the other on the air tube. Tighten both clamping screws to grip both the sprayhead and air tube.
6. Temporarily insert the free end of the air tube into the flexible air duct from the mistblower.
7. Put on the knapsack mistblower and hold the sprayhead at the correct angle for the crop or pest to be sprayed. Cut the air tube (19) as required to give a comfortable position for the sprayhead when held by its handle. The sprayhead should also be rotated to the most convenient position.
8. Place a pipe clip (20) over the end of the flexible air duct and tighten the clip to grip the air tube.
9. Push the feed hose from the chemical tank on to the inlet fitting (17) of the control valve. Note that this fitting is stepped to accept varying sizes of hose. If necessary, the hose should be cut to length or replaced if it is too short. Secure the hose with the pipe clip (12) provided.
10. If using a fixed restrictor tube, select the appropriate flow restrictor tube (8) (see section 6) and fit this to the outlet of the on/off valve using the cap nut (14). If using the optional stepped flow restrictor valve, connect the outlet fitting of the control valve to the inlet of the restrictor valve using the hose provided and connect the inlet tube of the sprayhead to the outlet of the restrictor valve. Ensure that the filter (16) is in position.
11. Connect the atomiser feed hose (11) to the outlet of the flow restrictor and secure with a pipe clip (12).
12. Fill the tank with a non-toxic liquid (e.g. water for conventional application or kerosene for ULV) and run the sprayer for several minutes (see Operation section 4) to test for leaks.

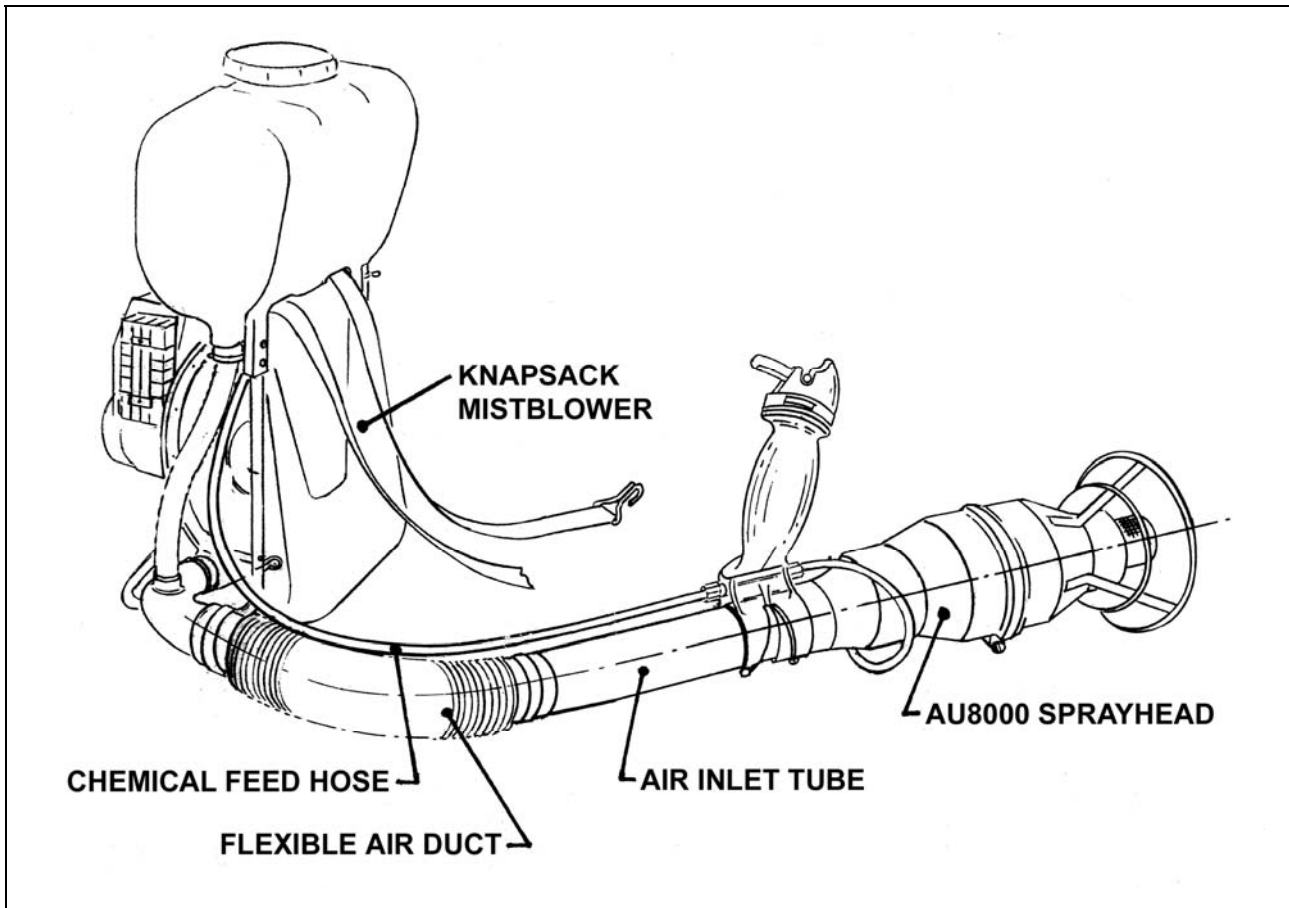

Fig. 1 – Attachment of AU8000 Sprayhead to Mistblower

4. OPERATION

This section describes the operation of an AU8000 sprayer with the knapsack mistblower supplied by Micronair. If the sprayhead is used with a different mistblower, some operating procedures may differ; refer to the mistblower manufacturer's instructions.

4.1. Operation of Standard Sprayer

1. Make up a mixture of 25 parts regular (NOT high octane) petrol (gasoline) and 1 part (4%) two-stroke oil. Standard engine oil should NOT normally be used. If two-stroke oil is not available, SAE 40/50 oil may be used for short periods. See mistblower instruction book for full fuel mixing instructions.
2. Close the fuel valve under the fuel tank and pour fuel (as mixed in step 1) into tank. DO NOT OVERFILL.
3. Ensure that the chemical control valve on the handle is closed with its lever parallel to the sprayhead.
4. Remove the cap of the chemical tank and check that the flexible air hose inside is pushed firmly onto the fitting at the bottom and into the filter at the top. Also check that the cap at the opposite side of the inside of the tank is pushed firmly in place.
5. Pour the required amount of chemical into the tank and replace the cap firmly.

6. Open the fuel valve.



Stop Switch

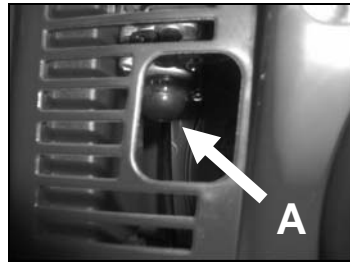

Primer

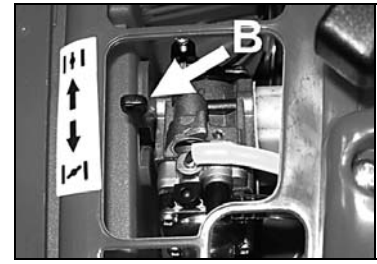

Choke Lever

7. Set the engine stop switch to the ON position (as shown above).
8. If the engine is cold, press firmly upwards on the carburettor primer bulb (A in picture above) ten times.
9. Move the throttle lever (below the engine stop switch) to the minimum speed position (toward the back of the sprayer).
10. If the engine is cold, move the red choke lever (B in picture above) fully downwards to the closed position.
11. Ensure that the sprayhead is in a safe place away from foliage or obstructions.
12. Put your left foot on the lower part of the sprayer frame and your left hand on the cap of the chemical tank to stabilise the machine. Pull gently on the recoil starter cord until you feel maximum resistance (the engine compression is at its maximum). Pull the cord rapidly and firmly until the engine starts. DO NOT pull the cord hard against its end-stop. Should the engine fail to start, do not allow the carburettor to become flooded with fuel. If the carburettor does become flooded, proceed as follows:
- Open the choke by moving the lever B fully upwards.
 - Close the throttle.
 - Pull on the starter cord 10 – 20 times.
 - Wait several minutes and repeat steps 7 – 12.
13. Allow the engine to idle for 15 – 20 seconds and then slowly move the choke lever (B) fully upwards to the open position.
14. Move the throttle lever to the mid position and allow the engine to run at approximately 50% of its maximum speed for one minute.
15. Set the throttle lever so that the engine idles smoothly.
16. Lift the knapsack mistblower onto the operator's back. Note that the operator must hold the sprayhead and NOT let it drag on the ground. This operation is easiest with two people. However, the operator can put the knapsack on alone if it is first lifted onto a waist-high surface.
17. When in the spraying area, set the throttle lever to its maximum position. DO NOT run the engine for a prolonged time at half-throttle or idling.
18. Turn the flow of chemical on and off with the valve on the handle. The lever of this valve may either be pressed down against its spring for intermittent operation or may be raised to a locked position for continuous spraying.

19. Only open the chemical valve when the mistblower is running at its normal operating speed. Opening the valve when there is no airflow can result in a build-up of chemical inside the sprayhead and the risk of contamination or plant damage when the airflow is increased.
20. The sprayer must always be directed DOWNWIND of the operator and each pass through the sprayed area must be UPWIND of previous passes. This ensures that the operator is always walking through an unsprayed area and cannot be contaminated by any spray blown back by the wind.
21. The sprayer should be held at a distance of at least 1m (3 ft) from the target whenever possible. This ensures an even distribution of spray droplets and minimises the risk of damage to vulnerable crops by high velocity air from the sprayhead.
22. The rotating gauze of the atomiser should not be allowed to come into contact with foliage or the operator.
23. When using a ULV drift spraying technique to give a wide swath in open terrain (e.g. locust or armyworm control), the sprayhead should be held at an angle of about 30 degrees above the horizontal. This allows the wind to carry the spray from the maximum height to achieve the widest swath.
24. Set the throttle lever to the idle position after closing the chemical valve if the sprayer is not to be used for more than one or two minutes. However, do not allow the engine to idle for a prolonged period (see point 17 above).
25. To stop the engine, move the throttle lever to the fully closed position and allow the engine to idle for one minute before setting the engine stop switch to the STOP position.
26. The entire sprayer, including the AU8000 sprayhead, must be thoroughly cleaned after use. If ULV chemicals have been used, they must be removed with a suitable solvent such as kerosene. Water is only suitable if water based formulations have been used. Before cleaning the outside of the sprayer, the tank, hoses and sprayhead must be flushed out by spraying about 2 litres of water or solvent from the mistblower.

4.2. Operation of Sprayer with Optional Boost Pump

This section applies only to sprayers fitted with the optional chemical boost pump.

1. Before starting the sprayer, ensure that the boost pump lever is DISENGAGED (see Fig. 2).
2. Start the sprayer as described in section 4.1.
3. When in the spraying area, move the boost pump lever to the ENGAGED position and proceed as described in section 4.1.
4. If possible, avoid completely emptying the spray tank. Should the tank become empty, DISENGAGE the boost pump IMMEDIATELY to avoid the possibility of damage by running dry.

NOTE: The output of the sprayer with the pump running will be higher than with no pump. See section 6.1 for full details.

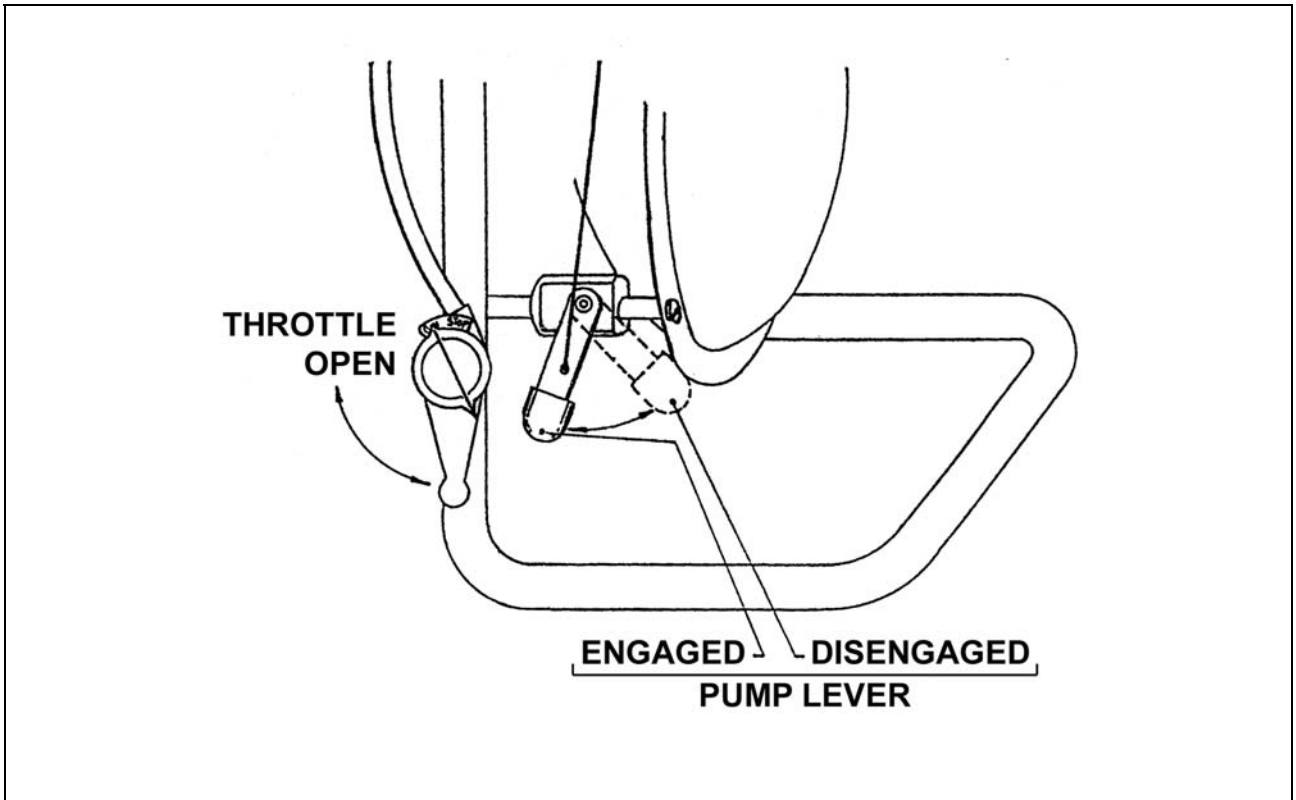

Fig. 2 – Controls for Throttle and Boost Pump

5. HEALTH AND SAFETY

The AU8000 sprayer must be used by a qualified operator in accordance with the recommendations and statutory requirements for the use of sprayers and the chemical being sprayed.

These requirements will be set out in the applicable local legislation and in the label of the chemical.

In the United Kingdom, the precautions and regulations concerning the use of pesticides and sprayers are defined in the Code of Practice for the Use of Pesticides on Farms and Holdings (Published by HMSO for the Ministry of Agriculture, Fisheries and Food and the Health and Safety Commission).

The use of pesticides and sprayers are subject to legislation or codes of practice in most other countries. It is the responsibility of the user to ensure that these are read, understood and complied with.

The following recommendations are for guidance only and do not exclude any statutory requirement:

1. Always wear adequate protective clothing, eye protection and respiratory protection when mixing, transferring or spraying pesticides. The minimum level of protection will be stated on the chemical label or in the Code of Practice in most countries.
2. Protective clothing, respirators etc must be removed as soon as exposure to pesticides has ceased. All items must be washed or disposed of safely according to the manufacturers' recommendations.
3. Ensure that the sprayer is correctly calibrated for the chemical, application technique and crop or pest being sprayed.
4. Take note of the speed and direction of the wind. Ensure that spray droplets do not drift on adjacent crops, another person's land or an inhabited area. Always spray downwind to avoid operator contamination. Never walk through a sprayed area.
5. All traces of chemical must be washed from the operator's skin immediately after spraying and before eating, drinking or smoking.
6. Remove all traces of chemical from the tank, pipework and sprayhead as well as from external surfaces of the sprayer.
7. All residues of chemical from the sprayer, pesticide containers or mixing vessels etc must be disposed of safely by an approved means. Do not contaminate an off-target area or allow pesticides to reach streams, wells or groundwater.
8. Dispose of empty chemical containers safely by an approved means. Do not keep containers for re-use for other purposes.

6. CALIBRATION

As with any mistblower, an AU8000 sprayer must be calibrated before use. This involves setting the correct output rate of chemical and adjusting the sprayhead to produce the appropriate droplet size for the chemical and application technique being used.

The following sections describe the calibration of a standard Micronair AU8000 sprayer. Some details of the procedures may differ if the sprayhead is used with a different model of mistblower.

6.1. Output Rate of Chemical

The output rate of chemical from the sprayer will be determined by the required application rate (in litres/hectare) and the area sprayed per minute (in hectares/minute).

The flow of chemical from the atomiser is controlled by either by the interchangeable restrictor tube attached to the on/off valve or by an optional stepped variable restrictor valve. The pressure of the chemical also affects the flow rate. Chemical is pressurised by air from the blower fan and by the optional boost pump (if fitted).

The following steps describe the calibration procedure in detail:

1. Establish the average walking speed of the operator. This will depend upon, for example, the target being sprayed, the evenness or slope of the ground, the amount of chemical carried and the temperature.

The most accurate means of assessing walking speed is for the operator to spray the actual crop or target in a 'trial run' with clean water. The speed can then be calculated from the time to cover a measured distance.

2. Establish the width of the swath of spray on the target. In row crops or orchard spraying this can often be determined by the number of rows sprayed at a time. In public health or pest control spraying using a drift technique over open ground the swath width must be determined by the use of sensitive cards or paper. These should be placed both horizontally and vertically. The cards should be mounted downwind of the spray line. The sprayer must be used under typical conditions of wind and temperature.

When spraying field crops or open areas (e.g. for locust control), the distance between successive passes of the sprayer should be less than the measured maximum swath width to ensure adequate overlap of the spray and allow for variations in the wind and terrain. For the purposes of calibration, the distance between passes should be regarded as the swath width.

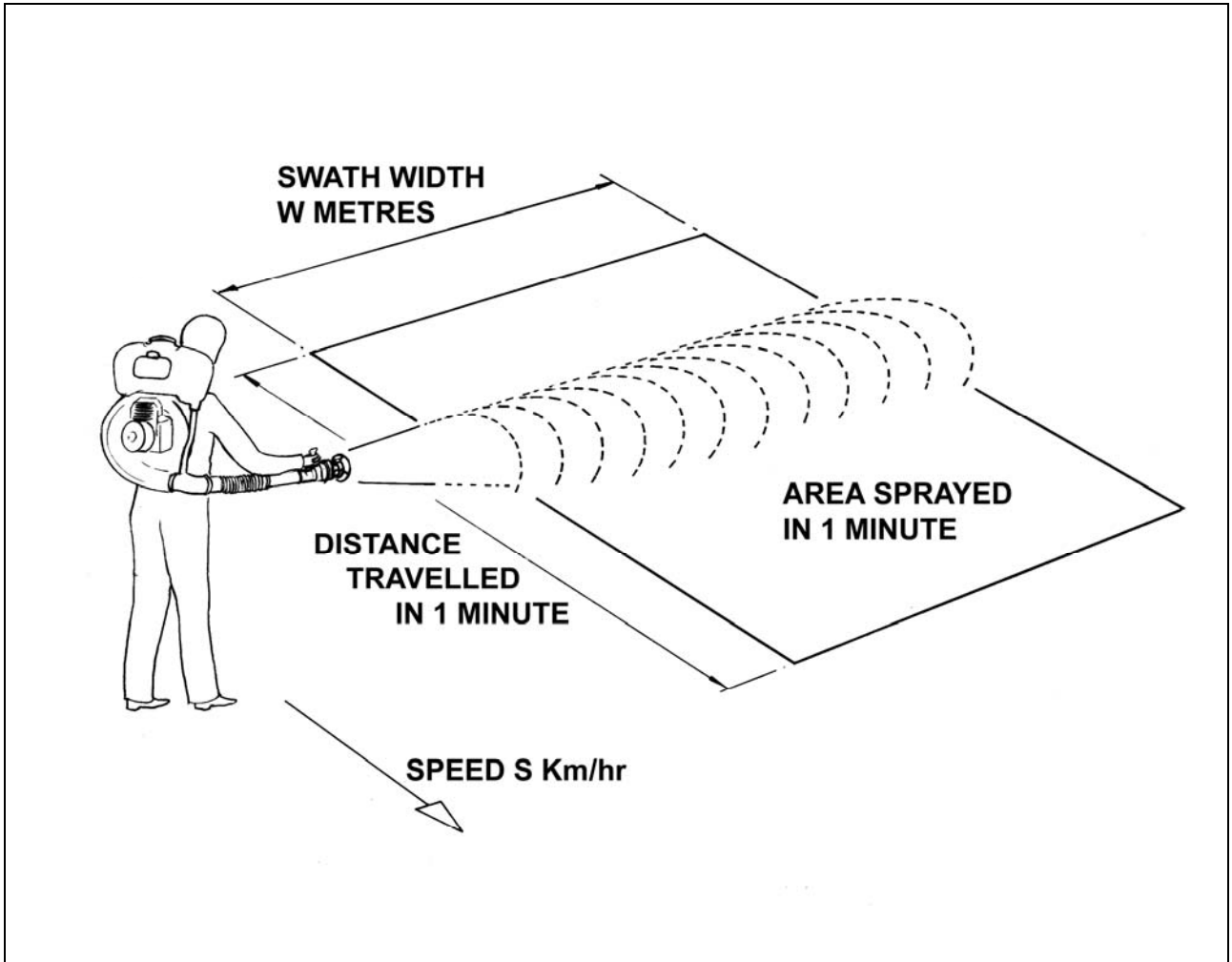

Fig. 3 – Coverage of Sprayer

3. Calculate the area treated by the sprayer per minute. Fig. 3 shows the sprayer being operated over a field crop.

If the operator is walking at S Km/Hr this corresponds to $1000 \times S$ metres/hour:

$$\text{Distance travelled} = \frac{1000 \times S}{60} \quad \text{metres/minute}$$

If the width of the swath is W metres, then the area treated per minute is:

$$\text{Area treated} = \frac{1000 \times S \times W}{60} \quad \text{sq metres/minute}$$

This is converted to hectares by dividing by 10,000:

$$\text{Area treated} = \frac{1000 \times S \times W}{60 \times 10,000} = \frac{S \times W}{600} \quad \text{ha/minute}$$

This gives the standard formula for calculating the coverage of a sprayer:

$$\text{Area/min} = \frac{\text{Swath Width (m)} \times \text{Speed (Km/Hr)}}{600} \quad \text{ha/min}$$

Example:

Speed: 4 Km/Hour
Swath Width: 12 m

Therefore:

$$\text{Area treated} = \frac{S \times W}{600} = \frac{4 \times 12}{600} = 0.08 \text{ ha/min}$$

Table 1 shows the coverage of the sprayer for various swath widths and spraying speeds.

4. Calculate the required output from the sprayer in litres/minute to give the correct application rate for the chemical being used.

The output rate of chemical is given by the area sprayed (in hectares) per minute multiplied by the required application rate in litres per hectare.

Example:

Coverage: 0.08 ha/min
Application rate: 2 litre/ha
Output = 0.08 x 2 = 0.16 litre/min

Speed Km/hr	SWATH WIDTH (METRES)							
	2	5	10	15	20	25	30	50
2	0.007	0.017	0.033	0.050	0.067	0.083	0.100	0.167
3	0.010	0.025	0.050	0.075	0.100	0.125	0.150	0.250
4	0.013	0.033	0.067	0.100	0.133	0.167	0.200	0.333
5	0.017	0.047	0.083	0.125	0.167	0.208	0.250	0.416

Table 1 – Coverage of Sprayer in Ha/min

5. If using the interchangeable restrictor tubes, select the correct restrictor tube to give the required flow rate. Table 2 gives the typical flow rate for each restrictor tube both with gravity feed and with the optional boost pump operating. These figures are based on measurements with water. Actual flow rates will depend upon the viscosity of the chemical being used. When the boost pump is not used, the flow rate will also be affected by the height of the sprayhead relative to the chemical tank. The rates in Table 2 are measured with the tank half full and the sprayhead level with the engine.

RESTRICTOR NUMBER	FLOW RATE (LITRES/MINUTE)	
	Without boost pump	With boost pump
1	0.075	0.40
2	0.150	0.80
3	0.300	1.60
4	0.600	
5	1.200	

Table 2 – Approximate Flow Rates for Restrictor Tubes

Fit a restrictor tube (8) to the outlet of the valve. Tighten the cap nut (14) firmly by hand.

6. If using the optional stepped variable restrictor valve, rotate the knob to select the index number corresponding to the flow closest to that calculated in step (4) above. Note that the selector knob 'clicks' to each setting. The knob should not be set to a position between the index marks. Table 3 shows the approximate flow rate for each setting of the restrictor valve with the tank half full and the sprayhead level with the engine.

SETTING NUMBER	FLOW RATE (LITRES/MINUTE)	
	Without boost pump	With boost pump
1	0.150	0.750
2	0.250	1.250
3	0.400	1.800
4	0.550	
5	0.750	

Table 3 – Approximate Flow Rates for Variable Restrictor Valve Settings

7. Push a 15 cm (6") length of 6 mm (¼") inside diameter plastic hose over the outlet of the restrictor tube or disconnect the outlet fitting of the variable restrictor valve..
8. Ensure that the chemical on/off valve is closed.
9. Fill the tank of the mistblower to half its normal working capacity with the chemical to be used.
10. Start the engine of the mistblower and run it at the correct operating speed (see section 4.1).
11. Support the sprayhead at its normal operating height.
12. Place a container under the tube fitted in step (7) and open the chemical on/off valve until all air has been purged from the hose and valve. Close the valve.
13. Open the chemical valve again and collect chemical for a measured time of one or two minutes. Use a measuring cylinder or calibrated container to measure output rate in litres per minute.
14. Compare the measured output rate with the calculated rate from step (4).
15. If the actual output is slightly too high or too low, it may be possible to adjust it by varying the tank air pressure control of the mistblower.
16. If this adjustment is insufficient or does not exist, the restrictor tube must be changed to a smaller size to reduce the flow or a larger size to increase the flow.
17. The flow must always be re-checked after making any adjustments to the restrictor or tank air pressure.

The above procedures assume that the operator can walk at a steady speed whilst spraying. This may not be possible under some circumstances, such as when spraying large trees. In these cases, the calibration and spraying techniques should be modified as follows:

1. Calculate the number of trees per hectare.

2. Divide the chemical application rate in litres/Ha by the number of trees per hectare to give the dose of chemical per tree.

Example:

Planting:		400 trees/ha		
Application rate:		200 litre/ha		
Dose	=	$\frac{200}{400}$	=	0.5 litre/tree

3. Measure the time taken to spray one tree from all directions. Note that an adequate time must be allowed for the airstream to carry spray droplets into the higher foliage.
4. Calculate the flow rate required to deliver the required dose in the measured time.

Example:

Dose:		0.5 L/tree		
Time:		1.5 min/tree		
Output	=	$\frac{0.5}{1.5}$	=	0.33 litre/min

5. Calibrate the sprayer as described earlier.

6.2. Adjustment of Droplet Size

The size of the droplets produced by the sprayhead depends upon the rotational speed of the atomiser and the properties of the chemical. The speed of the atomiser is controlled by the velocity of air from the blower fan and by the angle of the fan blades.

As the mistblower is designed to run at a fixed blower speed, the speed of the atomiser must be set by adjusting the angle of the fan blades.

All AU8000 sprayheads are supplied with the fan blades pre-adjusted to angle setting number 2 (see Fig. 4). This setting should be satisfactory for the majority of applications.

If the droplet size is found to be too small, it can be increased by reducing the speed of the atomiser by setting the fan blades to a coarser angle. Similarly, the droplet size can be reduced by setting the fan blades to a finer angle and increasing the speed of the atomiser.

The atomiser blade angle can be changed as follows. Numbers relate to Fig. 5.

1. Remove the screw securing the V-clamp ring (15) around the outer casing of the sprayhead. Remove the front casing (2).
2. Remove the atomiser support ring (3) and atomiser from the rear casing whilst pushing the feed hose through the grommet in the casing.
3. Remove the pipe clip (12) and atomiser feed hose (11). Slide the cone (5) off the support ring.
4. Slacken the four atomiser clamp ring securing screws (118) just sufficiently to allow the atomiser fan blades to be adjusted, see Fig. 6.

5. Adjust all four blades of the atomiser to a finer or coarser angle as required. See Fig. 4 for positions of setting marks. The blades should not be set finer than position 1 or coarser than position 6. NOTE: For accurate alignment, the graduation mark and the split line, view through the 10 mm hole in the atomiser support ring.
6. Tighten the clamp ring screws just sufficiently to trap the fan blades and prevent them from moving. A torque of 0.3 nm (1 lb in) is sufficient. Overtightening the screws could distort the hub or clamp ring.

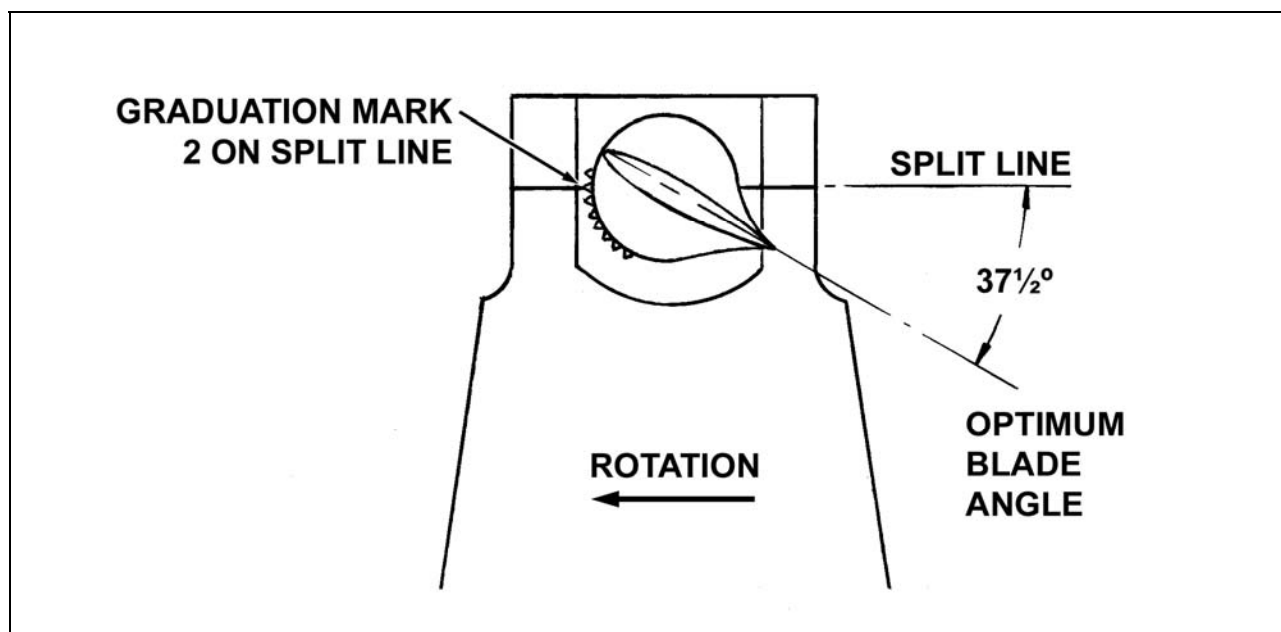

Fig. 4 – Setting Marks on Blade

7. Reassemble the sprayhead by reversing steps (1 – 5).
8. Carry out a test by spraying the actual chemical to be used onto sensitive cards, paper or slides. Check that the spray deposit is appropriate for the chemical and application technique. Note that sensitive cards only give a good indication of the number of droplets larger than about 60 microns. Smaller droplets may not mark some types of card. The apparent size of droplets on the card will be larger than the actual size due to spreading on the surface.
9. Note that the end cap of the gauze is provided with a conical recess in the centre. This is intended to drive a hand-held tachometer to measure the speed of the atomiser if required.

7. MAINTENANCE

Both the AU8000 sprayhead and the knapsack mistblower are designed for maximum reliability and for a minimum of simple maintenance.

The following sections cover the sprayhead and general guidance for the mistblower supplied with complete sprayers. Please refer to the Cifarelli maintenance manual for full details of maintenance of the mistblower. If an alternative mistblower is used, refer to the manufacturer's maintenance instructions. The parts lists for the sprayhead and atomiser are shown in section 8.

7.1. Knapsack Mistblower – Routine Maintenance

The mistblower will have a long and trouble-free life if it is kept clean and properly adjusted. Attention must be given to the following points:

1. Chemical must NEVER be left in the tank or pipework. Always flush out the sprayer with water or a solvent for the chemical used. Drain cleaning liquid from the sprayer before storage.
2. Do not leave fuel in the tank or carburettor whilst the sprayer is in storage. After use, close the fuel valve whilst the engine is running. When the engine stops, drain all remaining fuel from the tank.
3. Check and clean the engine air filter every 50 hours (or less in dusty conditions). To clean the filter, proceed as follows:
 - i) Open the filter casing and remove the foam filter.
 - ii) Wash the filter in petrol (gasoline).
 - iii) While still wet, pour about 5 ml of SAE 40/50 oil on the filter and squeeze well in.
 - iv) Allow all petrol to evaporate.
 - v) Re-assemble filter in casing.
4. Check and clean fuel filters. Note that the engine has two filters; one at the fuel valve and one at the carburettor inlet.
5. Check the spark plug every 50 hours. If necessary, clean the spark plug and adjust the gap setting to 0.4 – 0.5 mm. If the spark plug is damaged, replace with a new plug of the correct type (see mistblower parts list).

7.2. Possible Engine Faults and Remedies

ENGINE WILL NOT START

Fault	Remedy
1. Fuel valve closed	<i>Open valve</i>
2. Lack of fuel	<i>Add fuel</i>
3. Hole in the fuel tank cap obstructed	<i>Open hole</i>
4. Engine flooded	<i>See starting instructions</i>

- | | | |
|----|--------------------------------------------------------------|--------------------------------------------------|
| 5. | Filter in the fuel cock or at the carburettor inlet is dirty | <i>Clean filters</i> |
| 6. | Carburettor float needle blocked | <i>Clean and check that needle slides freely</i> |
| 7. | Spark Plug contaminated with oil or carbon | <i>Clean</i> |
| 8. | Spark plug gap wrongly adjusted | <i>Adjust to 0.4 – 0.5 mm</i> |

UNSTEADY ENGINE RPM OR TENDENCY TO STOP

- | Fault | Remedy | |
|--------------|---------------------------------------------|-------------------------------|
| 9. | Loose spark plug | <i>Tighten spark plug</i> |
| 10. | See points 5 - 8 above | |
| 11. | Ignition lead damaged or not making contact | <i>Fasten or replace lead</i> |

ENGINE IDLE UNSTEADY

- | Fault | Remedy | |
|--------------|----------------------------------------|---------------|
| 12. | Idle advance jet obstructed | <i>Clean</i> |
| 13. | Idle advance screw requires adjustment | <i>Adjust</i> |

ENGINE DOES NOT DEVELOP MAXIMUM POWER

- | Fault | Remedy | |
|--------------|------------------------------------------------------------------------|----------------------------------------------------------------------------|
| 14. | Carburettor jet contaminated | <i>Clean</i> |
| 15. | Spark plug contaminated | <i>Clean and check gap setting (0.4 - 0.5 mm)</i> |
| 16. | Choke closed. | <i>Move lever to position A (see starting instructions)</i> |
| 17. | Filter in the fuel valve or at the carburettor inlet is dirty | <i>Clean filters</i> |
| 18. | Air filter dirty | <i>Clean</i> |
| 19. | Exhaust hole obstructed. | <i>Remove exhaust and clean as far as the exhaust hole in the cylinder</i> |
| 20. | Air entering through gaskets of carburettor flanges, cylinder base etc | <i>Tighten screws and nuts, replace gaskets if necessary</i> |
| 21. | Wear of engine crankshaft seals | <i>Replace seals</i> |

EXCESSIVE VIBRATION

Fault	Remedy
22. Broken blade on blower rotor	<i>Check rotor (a quick inspection can be made by removing the rear cushion)</i>
23. Debris inside blower	<i>Open casing and clean</i>

7.3. Maintenance of Sprayhead

The AU8000 sprayhead is built from chemical resistant materials and its simple design and robust construction will ensure many years of trouble-free performance provided that it is not mistreated and is properly cleaned after use.

The AU8000 atomiser is dynamically balanced to ensure that it will run smoothly without vibration. Some chemicals, particularly certain ULV formulations, can dry or crystallise on the gauze, blocking the mesh and causing the atomiser to vibrate. This can easily be avoided by spraying 1 – 2 litres of liquid from the atomiser at the end of each spray job. The liquid must be a solvent for the chemical which has been used. Water will normally only dissolve water-based formulations. kerosene or diesel fuel is suitable for most ULV products.

The bearings of the AU8000 are sealed and are lubricated for life. The bearings should be replaced if they become worn.

If it is necessary to replace the bearings or any other part, the procedure to dismantle the sprayhead is as follows (see Fig. 5):

NOTE: DO NOT remove bearings unless worn.

1. Remove the inlet hose (11) from the restrictor tube on the chemical valve.
2. Loosen the handle clamping screws and slide the handle and sprayhead off the air inlet tube (19).
3. Remove the bolt of the V clamp (15) and remove the ring from the outer casing.
4. Pull the two halves of the outer casing apart and remove the atomiser (1) and its support ring (3). Push the feed hose through the grommet in the housing whilst withdrawing the atomiser
5. Remove the pipe clip (12), inlet hose (11) and cone (5).
6. Remove the pipe union (7) and atomiser securing nut (112). Slide the atomiser from the support ring.

To dismantle the atomiser, proceed as follows (see Fig. 6):

7. Remove the four screws (118) from the blade clamp ring (103), lift off the ring and remove the blades.
8. Remove the three screws (122) securing the cap and deflector assembly (105). Pull the cap from the end of the gauze and push the spindle (102) through the atomiser.

9. If it is necessary to remove the gauze, insert a screwdriver through the holes in the rear of the gauze and take out the three screws (120) securing the gauze to the hub.
10. If it is necessary to remove the bearings, use a pair of circlip pliers to remove the circlip (117) the wavy washer (121) and the sealing ring (110) from the front of the hub. Next, push an aluminium or brass drift against the inner part of the rear bearing and tap both bearings out through the front of the hub. Ensure that the hub (101) and spacers (106 and 107) are not damaged or lost.

After dismantling the atomiser, the following should be checked:

Gauze (104)	– Free of dents or chemical contamination
Bearings (113)	– Both in good condition. If one bearing is faulty, both must be replaced
Tolerance Rings (116)	– Not cracked or deformed
Bearing Spacers (106 and 107)	– Not corroded or worn
V-Ring Seal (114)	– In good condition and not cut or worn
Nilos Ring (115)	– Not worn or bent

Any worn and damaged parts must be replaced with genuine Micronair spares. Any attempt at local repair or the use of substitute parts could seriously damage the unit and impair its performance.

The procedure to re-assemble the atomiser and sprayhead is the reverse of the dismantling procedure. It is important that the following points are observed.

1. Fill the recess of the Nilos ring and the brass sealing (110) ring with grease. The bearings, spacers and lip of the V-Ring should also be coated with a thin film of grease before assembly.

NOTE: When new bearings are fitted a new Nilos ring should be fitted.

2. The bearings must be pressed squarely into the hub and must not be allowed to become mis-aligned. They must NOT be driven in with a hammer.
3. The clamp ring (103) must be assembled in the correct position with the dimples in the ring and hub body aligned.

NOTE: Item numbers 1 – 20 refer to Fig. 5 and item numbers 101 – 122 refer to Fig. 6.

8. PARTS LISTS

When ordering spare parts, please specify the following information:

- Serial number of sprayhead or engine
- Approximate date of purchase
- Description of part
- Part number as shown in this section
- Number of parts required

8.1. AU8000 Sprayhead

Item	Part No	Description	Quantity
1	EX3678	AU8000 Atomiser Assy	1
2	EX3682	Front Casing Assy	1
3	EX4032	Support Ring	1
4	EX3681	Rear Casing	1
5	EX4017	Cone	1
6	EX2192	Nut	1
7	EX3673	Nipple	1
8	EX4035-39	Restrictor Tubes	1 set (5)
9	CBP1712	'O' Ring	1
10	CBP1725	Grommet	1
11	CBP1637	Tube 5 mm bore 10 mm O/D	40 cm
12	CBP1634	Pipe Clip (½")	2
13	CBP1713	Handle Assy	1
14	CBP1714	Cap Nut	2
15	CBP1628	'V' Clamp	1
16	CBP1630	Filter	1
17	EX4040	Pipe Nipple	1
18	EX2275	Bush	1
19	CBP1661	Air Inlet Tube – Straight	1
20	CBP1717	Pipe Clip (2 ¾")	2

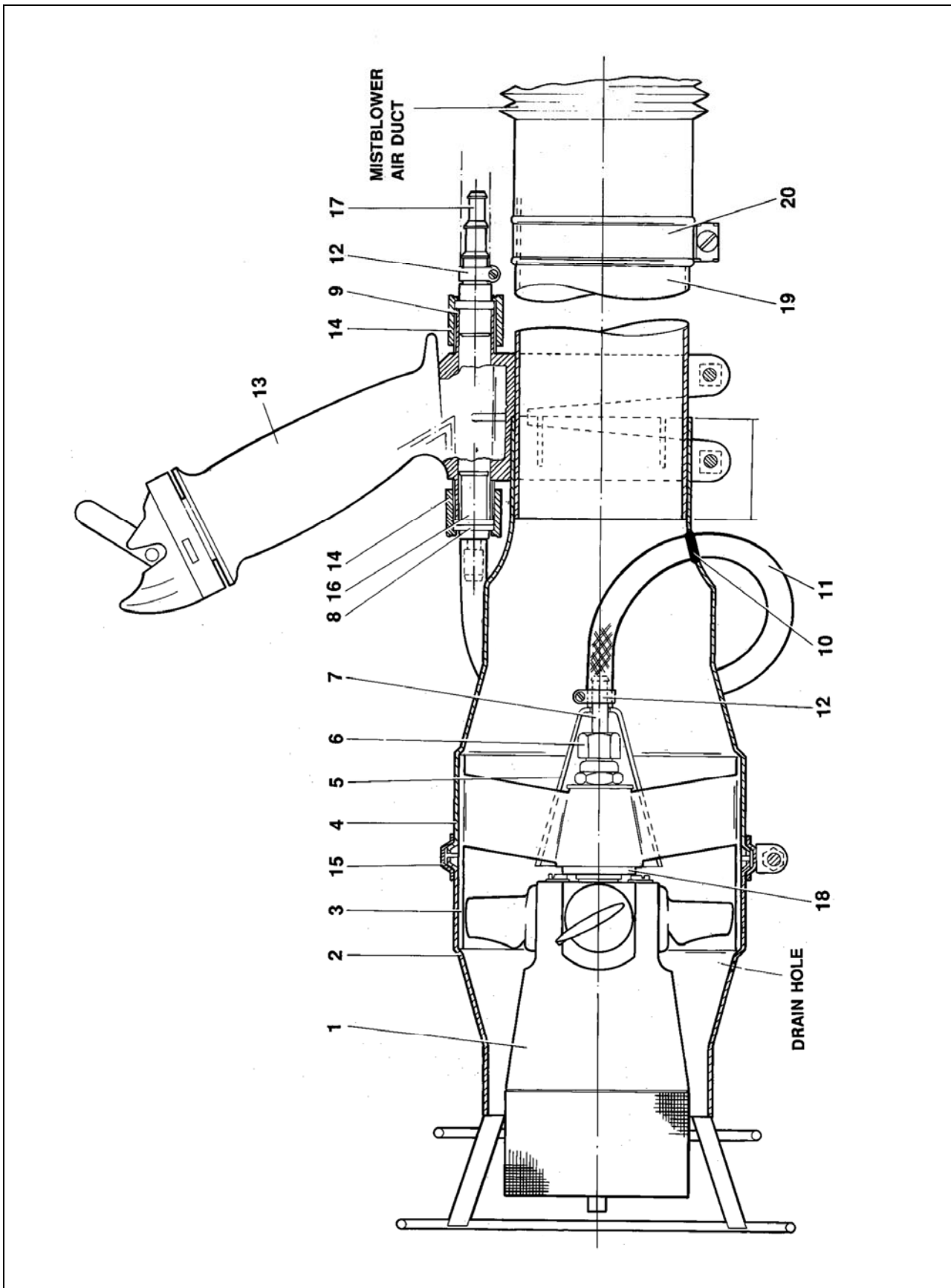

Fig. 5 – AU8000 Sprayhead

8.2. AU8000 Atomiser

Item	Part No	Description	Quantity
101	EX3666	Hub Drive Tube	1
102	EX3677	Spindle Assy	1
103	EX3669	Clamp Ring	1
104	EX3676	Gauze Assy.	1
105	EX3775	Deflector Cap Moulded type	1
106	EX3685	Inner Spacer	1
107	EX3686	Outer Spacer	1
108	EX3670	Spacer Bush	1
109	EX4404	Blade	4
110	EX5044	Sealing Ring	1
111	CBP1416	Washer	1
112	CBP1721	Stiffnut	1
113	CBP776	Bearing	2
114	CBP777	V-Ring Seal	1
115	CBP774	Nilos Ring	1
116	CBP808	Tolerance Ring	2
117	CBP2107	Circlip	1
118	CBP1720	Screw	4
119	SP127C	Washer	4
120	EX2612	Bolt	3
121	EX5062	Wavy Washer	1
122	A206-C10	Screw	3

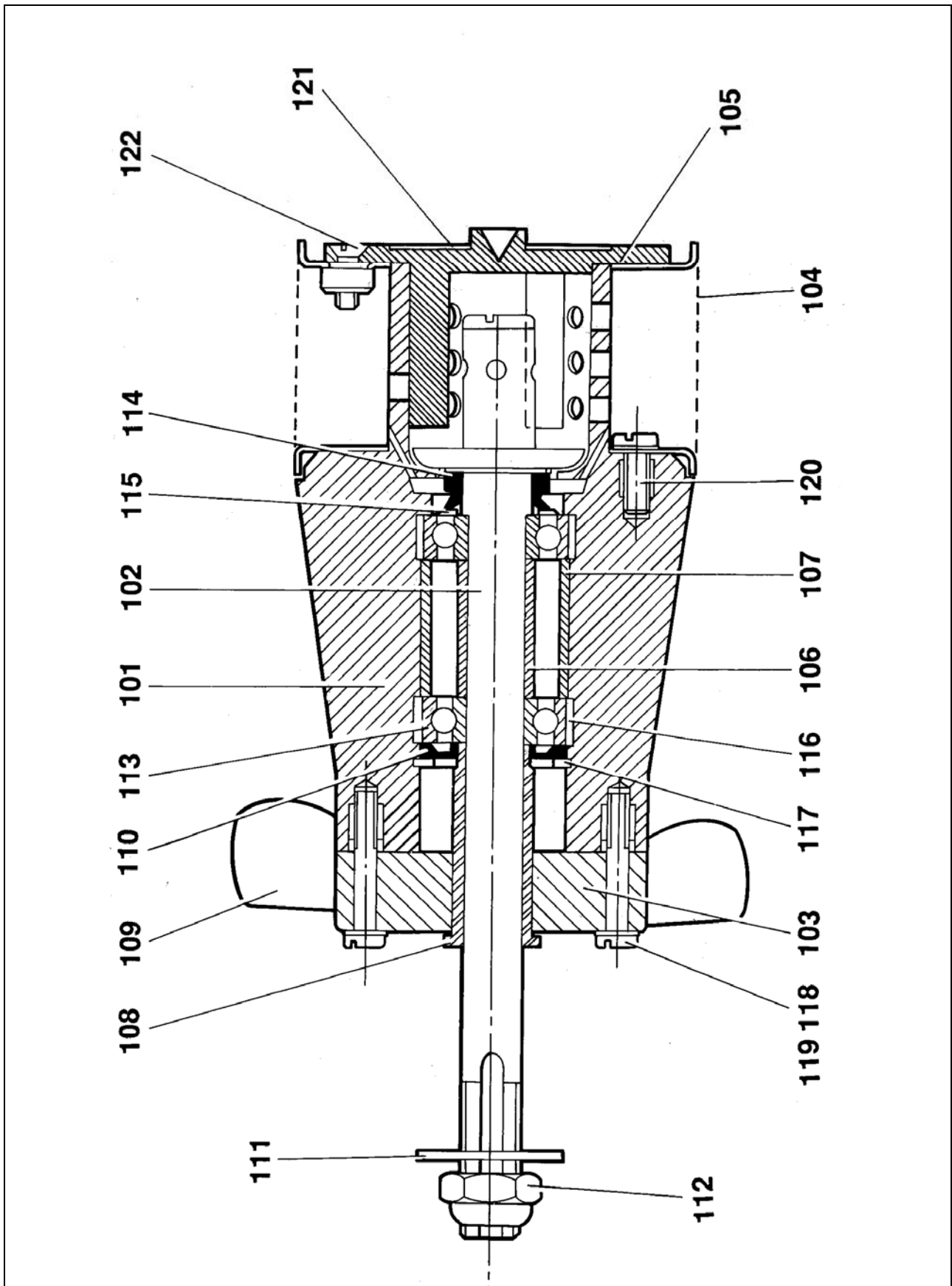

Fig. 6 – AU8000 Atomiser

9. CONVERSION FACTORS

1 yard	= 3 feet	= 0.91 metre
1 metre	= 39.37 inches	= 1.09 yards
1 statute mile	= 0.87 nautical mile	= 1.61 kilometres
1 nautical mile	= 1.15 statute mile	= 1.85 kilometres
1 kilometre	= 0.62 statute mile	= 0.54 nautical mile
1 statute mile	= 1760 yards	= 5280 feet
1 nautical mile	= 2027 yards	= 6081 feet
1 kilometre	= 1094 yards	= 3282 feet
1 metre/sec	= 2.237 miles per hr	= 196.9 ft/min
1 acre	= 43560 sq feet	= 4840 sq yards
1 acre	= 4047 sq metres	= 0.40 hectare
1 hectare	= 107600 sq feet	= 11955 sq yards
1 hectare	= 10000 sq metres	= 2.47 acres
1 sq mile	= 640 acres	= 259 hectares
1 sq kilometre	= 247 acres	= 100 hectares
1 US gal	= 0.83 Imp gal	= 3.78 litres
1 Imp gal	= 1.20 US gals	= 4.54 litres
1 litre	= 0.26 US gal	= 0.22 Imp gal
1 US pint	= 16 US fl ounces	= 0.47 litres
1 Imp pint	= 20 Imp fl ounces	= 0.57 litre
1 US gal/acre	= 8 US pint/acre	= 9.45 litres/hectare
1 Imp gal/acre	= 8 Imp pints/acre	= 11.35 litres/hectare
1 litre/hectare	= 0.11 US gal/acre	= 0.081 Imp gal/acre
1 pound	= 16 ounces	= 0.45 kilogram
1 kilogram	= 2.20 pounds	= 35.3 ounces
1 ounce	= 28.35 grams	
1 pound/sq inch	= 0.068 atmosphere	= 0.067 bar
1 atmosphere	= 14.70 pounds/sq in	= 1.01 bar
1 bar	= 14.50 pounds/sq in	= 0.98 atmosphere

Every care has been taken in the design of this equipment and the preparation of this Handbook. However, Micron Sprayers Limited cannot accept responsibility for errors or the consequences thereof. The user must satisfy himself that the equipment is suited to his needs and is performing according to his requirements.