

PARTS LIST / DIAGRAM

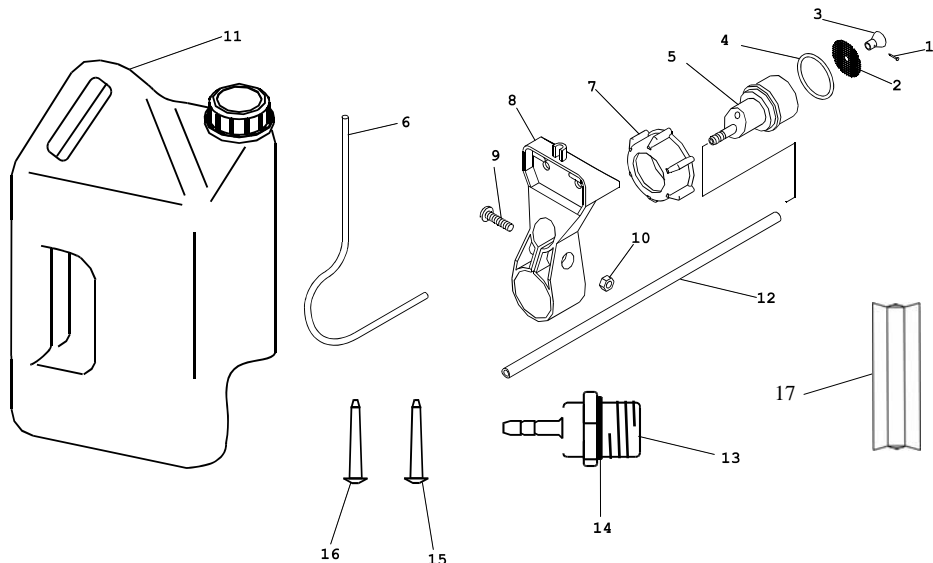

ITEM NO.	DESCRIPTION	PART NO.
1	Pin, 1mm x 10mm	5463
2	Filter, 40 mesh	4428
3	Air bleed deflector	5063
4	O'ring, BS125, viton	5148
5	Bottle connector	5752
6	Tube, 3/16" od, nylon - 0.45 m	3374/45
Items 1-6 above	Bottle connector assembly	5752 A
7	Bottle connector nut	5753
8	Battery case clamp	6126
9	Screw, M6 x 25, slotted	5787
10	Nut, M6	3691
11	Handy 5 l bottle, c/w cap	6167A
12	Tube, 5mm id x 8mm od – 0.86m	4309/86
13	Hose barb	5087
14	O-ring	4876
15	Feed nozzle, yellow	5383
16	Feed nozzle, orange	5384
17	Battery spacer (2 battery length)	BS-2

Iss: 4 03/03/05

ULVA+

**INSTRUCTIONS FOR THE
CONVERSION OF THE ULVA+
SPRAYER FOR USE WITH HERBICIDES**

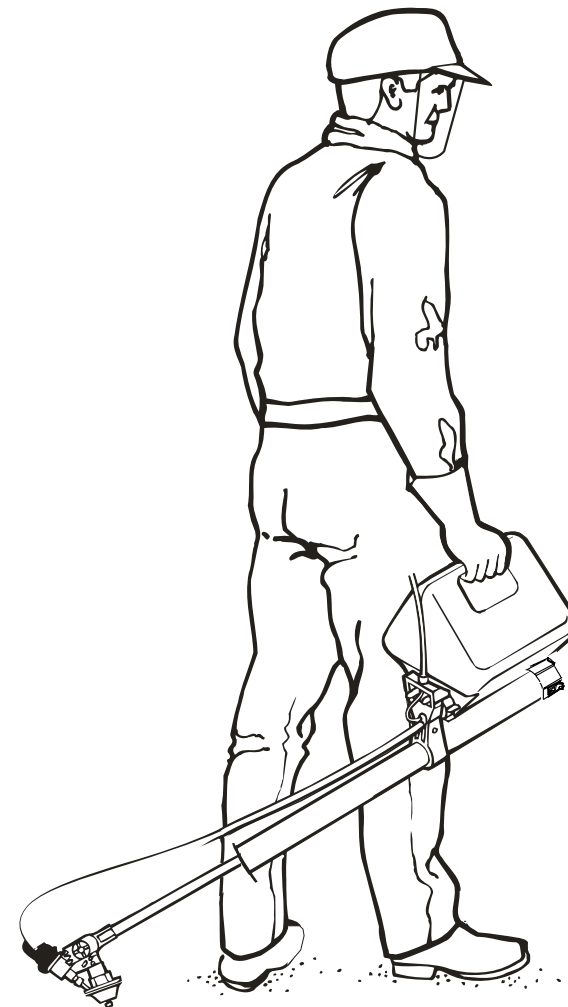

micron

Bromyard Industrial Estate, Bromyard,
Herefordshire, HR7 4HS, UK
Tel: + 44 (0) 1885 482397
Fax: + 44 (0) 1885 483043
E-mail: micron@micron.co.uk
URL: <http://www.micron.co.uk>

The ULVA+ sprayer can be adapted to apply herbicides with the addition of several accessories to produce the larger droplet size needed to minimise herbicide drift and enable the sprayer to be held behind the operator to minimise any risk of operator contamination.

The following items are provided by Micron as a kit for the conversion of the ULVA+ sprayer for use with herbicides:

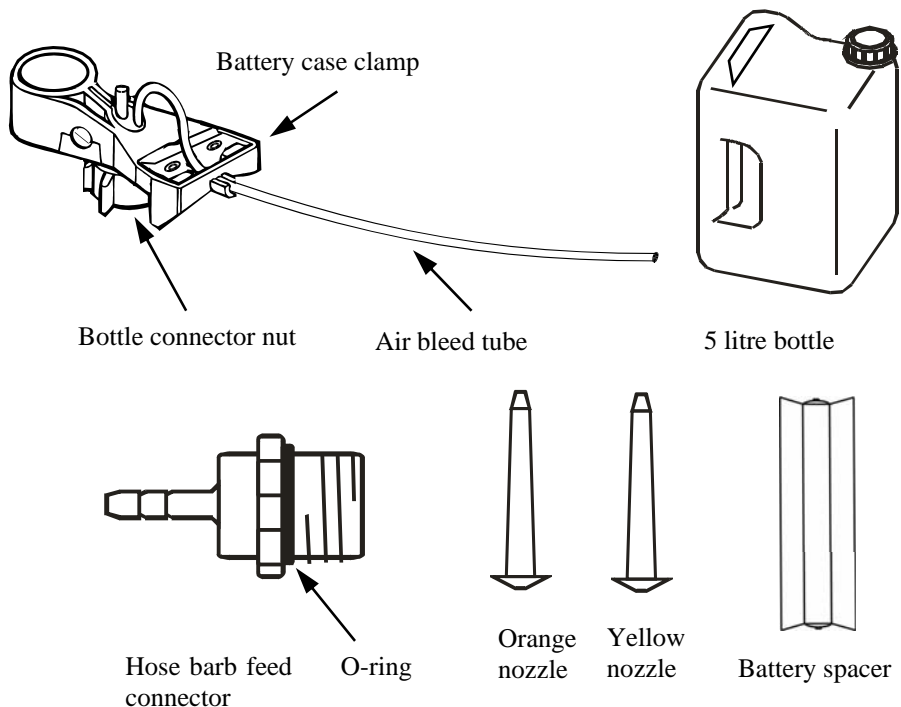

To prepare the ULVA+ for use with herbicides:

- 1 Remove the switch end piece and insert the battery spacer into the battery case together with 3 x D cell (R20S) batteries.



TO STOP SPRAYING

If there is any spray liquid left in the spray bottle, keep the motor running and slowly tilt the sprayer so that the head is above the level of the bottle and when no more spray liquid is emitted from the atomiser disc, switch off the sprayer. Do not raise the spray head above waist level with the disc still spinning as spray may continue to be emitted and contaminate the operator.

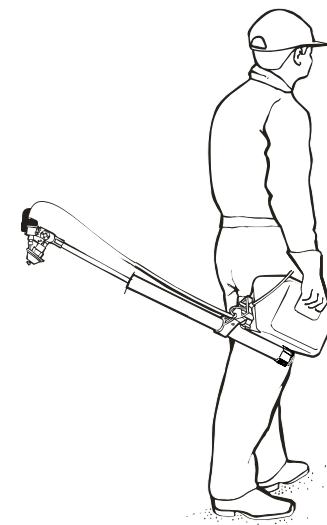

“Head Up” Position

AFTER SPRAYING

After spraying the sprayer should be thoroughly cleaned through with water and if possible a little soap. This is vitally important as residues of herbicide left in the ULVA+ could potentially damage another crop when it is sprayed with insecticide.

If the next use for the sprayer is for application of insecticide, the bottle, battery case clamp and battery spacer should be removed. Remove the hose barb feed connector and replace the one litre spray bottle.

Replace the original nozzle.

Make sure that the batteries are removed for storage and that the sprayer is stored in a clean and dry place.

BEFORE SPRAYING

Check the wind speed and direction (below 5 kph is safest). Take special care to avoid drift by keeping the spray head as low as possible.

Before spraying for the first time use soap and water **only** to familiarise yourself with the sprayer and to check the spray pattern produced.

TO START SPRAYING

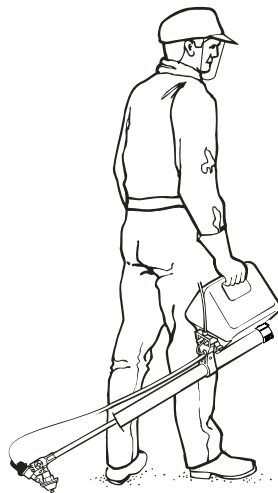

“Head Down” Position

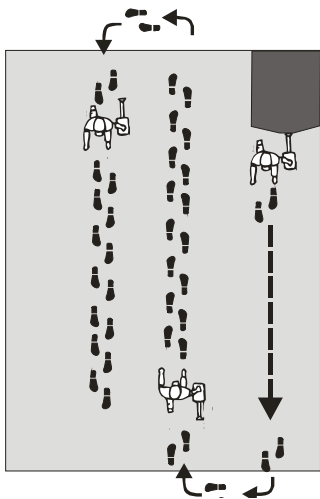

To start spraying, first switch on the motor and check that the atomiser disc is spinning (never touch the disc when it is spinning). Then, holding the spray bottle by the handle, tilt the sprayer backwards into the “head down” spraying position so that the spray head is below the level of the bottle. This allows spray liquid to flow onto the atomiser disc.

The battery case should be at an angle of around 35° to the ground with the spray head about 20 cm above the ground or top of the weed canopy. Make sure that the spray head is far enough behind you so as to avoid contaminating the back of the legs. Look behind to ensure that the sprayer is not leaking around the bottle connector nut and to confirm that spray is being pro-

duced. Start walking at the required speed. Occasionally glance behind to ensure that spray is being produced by the atomiser disc (if not the feed nozzle is probably blocked).

At the end of the row do not interrupt the liquid flow by turning the sprayer into the head up position, but continue application into the next row.

- 2 With the switch end piece still removed slide the battery case clamp and bottle connector over the battery case as shown. Push it up to the battery fixing screw and tighten the locking screw. Make sure that the feed outlet is correctly aligned with the head.

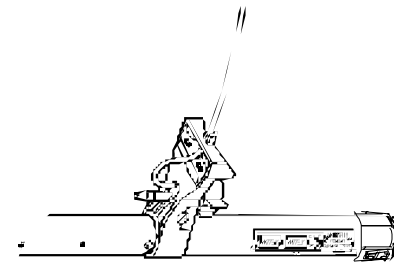

- 3 Remove the 1 litre spray bottle and replace with the hose barb feed connector as shown ensuring that the O-ring is in place. Fit the yellow or orange feed nozzle (see 'CHEMICAL MIXING AND FILLING').

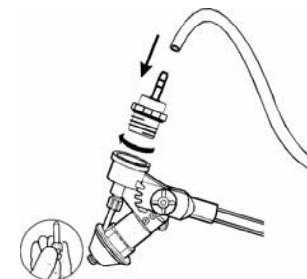

- 4 Connect the feed tube between the feed outlet on the bottle connector and the hose barb feed connector.

- 5 Adjust the head angle so that it is located on the bottom of the three notches as shown.

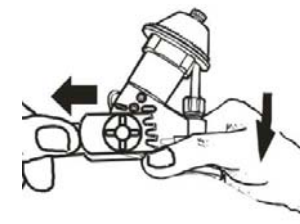

CHEMICAL MIXING AND FILLING

Herbicides are generally applied in higher volumes of water than insecticides – usually 20-30 litres of spray per hectare.

The table below gives suggestions for the nozzle, band width and walking speed combinations which give these application rates. Walking speeds will generally be faster when spraying herbicides as these are applied when the crop is short and passage is easier.

Total spray volume (l/ha)	Band width (m)	Feed nozzle	Flow rate (ml/min)	Walking speed (m/sec)
20	1.0	Yellow	135	1.125
25	0.8	Yellow	135	1.125
30	0.8	Orange	180	1.25

These flow rates have been measured using water only. Actual flow rates will depend on the viscosity of the spray liquid used and the angle at which the operator holds the sprayer. If the spray mixture is particularly viscous, therefore, the ULVA+ should be calibrated by the operator with the actual spray mix to be used.

To calibrate the ULVA+ remove the atomiser disc and collect and measure the volume of spray liquid dispensed in one minute with the sprayer held in the normal “head down” spraying position (see ‘TO START SPRAYING’). DO NOT switch the motor on. As the balance of the machine and hence angle at which it is held will vary as the spray bottle empties, an average flow rate will be obtained if measured with the bottle half full.

The formula below gives the relationship between band width, flow rate, walking speed and total spray volume:

$$\text{Flow rate (ml/min)} = 6 \times \text{total spray volume (l/ha)} \times \text{walking speed (m/s)} \times \text{band width}$$

Examples of spray mixing for one hectare:

a) glyphosate (360 g/l): 2 litres
 add water: 18 litres
 Total volume: 20 litres

i.e. 1 part glyphosate : 9 parts water
 e.g. 500 ml of glyphosate + 4.5 litres of water in 5 litre spray bottle

b) 2,4-D (500 g/l) 3 litres
 add water: +22 litres
 Total volume: 25 litres

i.e. 3 parts 2,4-D : 22 parts water
 e.g. 600 ml of 2,4-D + 4.4 litres of water in 5 litre spray bottle.

NOTE: DUE ITS HIGH TOXICITY PARAQUAT SHOULD NOT BE APPLIED THROUGH THE ULVA+ OR ANY OTHER LOW VOLUME SPRAYER

ALWAYS wear gloves when handling chemicals. **ALWAYS** use a funnel when filling the bottle.



1. Half fill the spray bottle with water



2. Measure out the exact amount of product and add to the spray bottle



3. Fill with water up to the 5 litre mark.

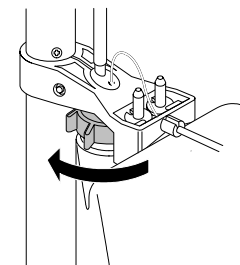

4. Attach the spray bottle to the battery case clamp making sure that the bottle connector nut is firmly tightened.

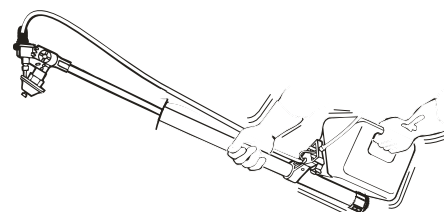

5. Shake the bottle to ensure thorough mixing - check for leaks.

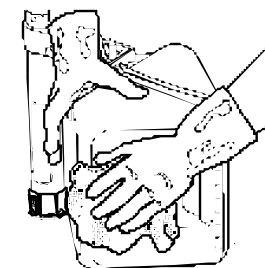

6. Wipe the bottle with a dry cloth.